

**RIDE
DRIVEN
YETI SINCE 1985
CYCLES**

YETICYCLES.COM

**RIDE
DRIVEN
YETI SINCE 1985
CYCLES**

2011 4X OWNER'S MANUAL

Table of Contents

Brand Overview	6
Frame Features	8
Geometry	10
Maintenance Schedule	12
Bike Setup Overview	14
– Shock Setup FOX RP23	16
– Quick Start Guide	17
– Cable Routing	18
Assembly Overview	20
– Assembly	22
– Disassembly Tips	26
Exploded Views	28
Part List	30
Warranty	32
Contact Information	33

Overview

WELCOME TO THE TRIBE

Congratulations on your purchase of a new Yeti bicycle and welcome to the Yeti Tribe. We are confident your new bicycle will exceed your expectations for value, performance and ride quality. Each frameset and component has been custom specified and designed to enhance your riding experience. Whether you are a beginner cyclist or a seasoned-pro, Yeti bicycles will provide endless hours of two-wheeled fun.

GENERAL INFORMATION

This model-specific manual is designed to be used in conjunction with the general Yeti Owner's Manual and the manuals supplied by the suspension manufacturers. If you did not receive the Yeti Owner's Manual or the manual provided by the suspension manufacturer, download the materials off the Internet, or contact your dealer.

Bicycling can be a hazardous activity even under the best of circumstances. Proper maintenance of your bicycle is your responsibility and when done properly helps reduce the risk of injury and damage to your bicycle. This manual outlines basic setup and maintenance recommendations of your new Yeti. Because it is impossible to anticipate every situation or condition that may occur during the assembly, setup and maintenance of your bicycle, Yeti recommends that all service and repairs be

performed by an authorized Yeti dealer.

This manual contains many "Warnings" and "Cautions" concerning the consequences of failure to maintain or inspect your bicycle. The combination of the safety alert symbol and the word "Warning" indicates a potentially hazardous situation in which, if not avoided, could result in serious injury or death. The combination of the safety alert symbol and the word "Caution" indicates a potentially hazardous situation in which, if not avoided, may result in minor injuries or damage to your bicycle or a component of your bicycle. Be sure to read and understand all "Warnings" and "Cautions".



Warning: Make sure you review and understand the warnings, instructions and content of this manual and accompanying manuals for your bicycle.



Warning: Technological advances have made bicycles and bicycle components more complex and the pace of innovation is increasing. It is impossible for this manual or accompanying manuals to provide all the information required to properly repair and maintain your bicycle. In order to help minimize the chances of injury, it is critical for you to have work performed by an authorized Yeti dealer.



Frame Features

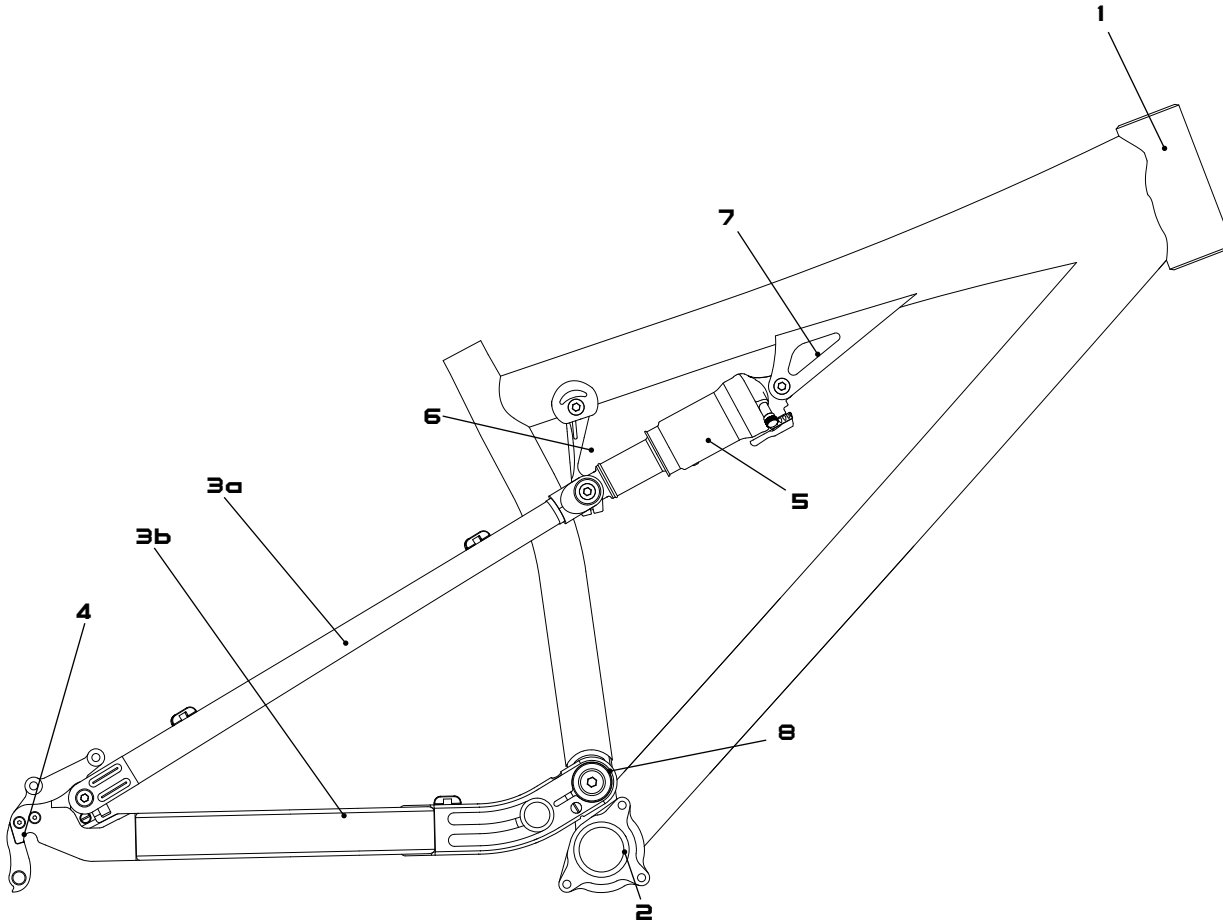

- PURE TUBING**
Yeti pure tubing is custom butted and tapered 7005 aluminum. This makes the frame lightweight and strong without the use of gussets. Unique shape provides added strength at the head tube junctions.
- BOTTOM BRACKET**
73mm shell, for use with a 113mm spindle.
- SEATSTAY (A) + CHAINSTAY (B)**
Oversized boxstays are stiff and strong and translate rider torque onto the dirt.
- REPLACEABLE DERAILLEUR HANGER**
Allows for quick replacement hanger in case of damage.
- SHOCK**
6.5" eye-to-eye / 1.5" stroke.
- DOGBONE**
Dogbone controls suspension rate and enhances rear end stiffness. Sealed bearings allow the dogbone to move freely.
- MAIN PIVOT**
Oversized sealed bearings on main pivot for low maintenance and stiction-free performance.

Geometry

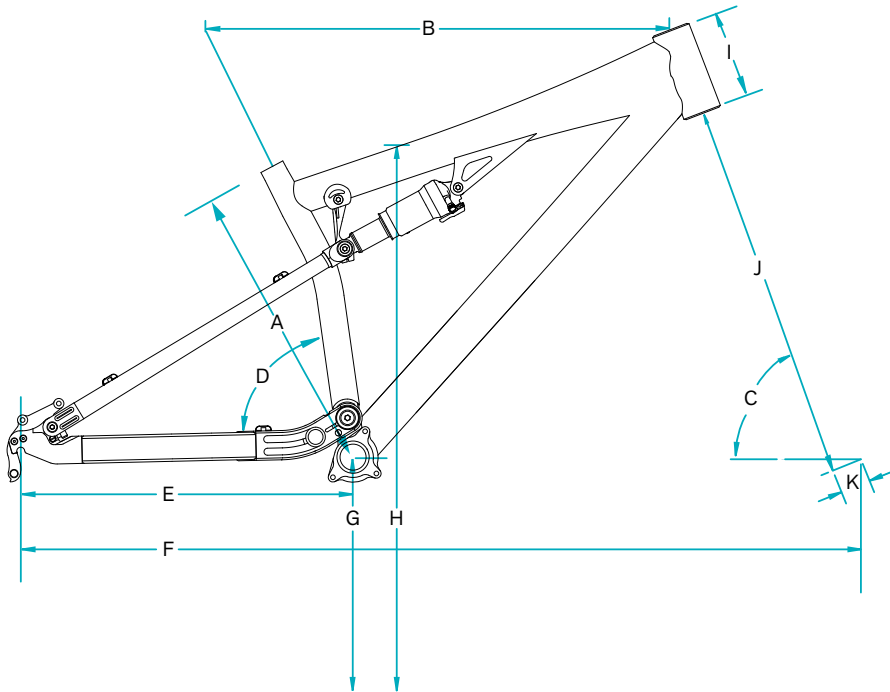

GEOMETRY 4X

100 MM FORK

	S	L
A	15.1	15.1
B	22	23.5
C	69	69
D	71	71
E	16.5	16.5
F	41.3	42.8
G	13	13
H	29.7	29.7
I	4.5	4.5
J	18.5	18.5
K	1.5	1.5

*All measurements are in inches.

Maintenance

MAINTENANCE Following these guidelines will help maintain the performance of your bicycle and prevent more serious problems from arising. It is important to remember that service intervals can vary depending on climate, trail conditions and riding frequency.

ACTION	WEEKLY	MONTHLY	3 MONTHS	ANNUALLY
Clean and lube chain	x			
Check tire pressure	x			
Clean bike of mud and debris (never spray water directly into frame or components)	x			
Check brake function	x			
Check shock pressure, if applicable	x			
Check for loose bolts and tighten, if necessary	x			
Check headset and tighten / loosen, if necessary		x		
Thoroughly clean pivot points with a rag (do not lubricate)		x		
Replace brake pads, if necessary			x	
Check tires for wear			x	
Check spoke tension and retention, if necessary			x	
Check chain for worn, damaged, or loose links, replace chain if necessary			x	
Complete tune-up performed by an authorized Yeti dealer				x



MAINTENANCE? Not sure how to work on your own bike? Contact your authorized Yeti dealer or visit www.parktool.com and check out the repair help section. This section contains detailed instruction on many of the service items listed in the maintenance schedule.

TORQUE We have attached a brief list of torque specifications for bolts and components that may need to be tightened while performing basic maintenance. This is just a guide. For specific torque specifications, please contact the component manufacturer directly.

TORQUE SPECS

Pivot Bolts	125 - 150
Derailleur Hanger Bolts	30 - 45
Handlebar Binder Bolt	150 - 180
Stem Binder Bolt	175 - 260
Seatpost Binder Bolt	150 - 180
Saddle Clamp Bolts	175 - 250
Rear Derailleur	70 - 86
Front Derailleur Clamp	45 - 60
Chainring Bolts	88 - 132



Caution: The torque specifications listed should be used as a guide when performing maintenance. Technological advances have made bicycles and bicycle components more complex, and the pace of innovation is increasing. Because of these advances, Yeti recommends that you refer to the torque specifications of the manufacture's component you are adjusting. In order to help minimize the chances of injury, do not perform any maintenance that you are not confident can be completed within your abilities.

Bike Setup



TOOLS NEEDED

- Shock pump
- Tape measure
- 4mm allen key

TIME

15-20 minutes

YETI TIPS

- Inspect your shock for any visible damage. If oil is leaking or you notice any damage to the surfaces or seals, please contact the Fox Racing Shox service center for repair at 800.FOX.SHOX.
- Shock set-up can fluctuate greatly based on the rider. The set-up guide is intended as a base line to get the rider started. Experiment with your settings to find the set-up that works best for you.



Setup-Fox RP23

Quick Start Guide

1 AIR PRESSURE The main air spring controls the sag of the shock. For the 4X to ride properly it is important to setup the shock with the correct amount of sag. For proper setup use 10-15% of the shock stroke. To increase sag, reduce the main spring air pressure. To reduce sag increase the main spring air pressure.



2 SAG Once you have set your baseline air pressure you need to measure the sag. To measure the sag slide the travel indicator (O-Ring) up against the shock body. With a friend supporting the bike, sit on the saddle (do not bounce) and allow your body weight to compress the shock. Once you have compressed the shock, get off the bike and measure the distance between the shock body and the new position of the travel indicator (O-Ring). This is your sag. Refer to the guide below for the percentage of sag equivalents for the measurement recorded.



3 PRO-PEDAL The pro-pedal dampening has three levels of adjustment and is controlled by the blue lever (formerly the lock-out lever). The three different levels of dampening are light, medium and heavy pro-pedal.

We recommend setting the pro-pedal in the middle of its adjustment range (position 2). If you feel like the bike is too firm and is not absorbing the small bumps, flick the lever left to the light setting. If the bike feels sluggish and you want the suspension to feel more efficient, turn the lever right to the stiffer setting.



4 REBOUND The rebound adjustment has a nine-click range. The rebound knob is the red adjustment dial located above your blue pro-pedal adjustment lever. As a general rule, adjustments that are too fast (counter-clockwise adjustment) will produce a springy ride with excessive kick-up of the rear end causing a bucking sensation. Adjustments that are too slow (clockwise adjustment) will cause packing of the rear wheel indicated by a sluggish ride feeling ride.

Slower rebound - turn the knob clockwise
Faster rebound- turn the knob counter-clockwise



SETUP OVERVIEW The 4x is designed to be used as a race/jump specific ride. This required a different setup on the rear shock than the standard full suspension ride. Essentially the ride is setup much stiffer, running lower sage percentages. This will require the rider to measure the sag exactly so the intended ride characteristics are achieved.

SAG SETTINGS

Sag %	10	15
Measured (inches)	.150	.225

*EXTERNAL ADJUSTMENTS

Rebound	5 Clicks
Pro-Pedal Lever	On//Active
Pro-Pedal Knob	Position 3

*All quick start setting adjustments are clockwise rotation from all the way out or a full counter-clockwise position.



WHAT IS PRO-PEDAL? Pro-pedal is a compression tune that gives the right amount of low-speed compression to filter out unwanted rider-induced bob without sacrificing critical mid- and high-speed damping. No flushing through your travel, no wasted setup time, and no energy-sucking suspension movement. Just super efficient pedaling performance ready for hits of any size.

Cable Setup

The 4X has full cable housing. By using full cable housing, we have eliminated break points in the line of your shifter housing. This allows riders to experience better overall shifting performance by reducing the entrance of unwanted elements such as sweat and sediment. Use of full cable housing helps prevent corrosion from the elements and keeps the shifting smoother for a longer period of time.

Caution: The failure to properly route shifter housing can cause malfunction of the shift mechanism and unexpected shifting of gears.

1 REAR DERAILLEUR Start by getting a long piece of housing ready. Fit the housing from the rear shifter across the headtube through the first open cable guide on the underside of the downtube. Then fit the cable into the next guide on the underside of the downtube. Cross the cable to the outside of the dogbone into the cable guide on the seatstay. Finally run the cable down to the second guide on the seatstay and into the derailleurs stop.

We recommend using the plastic clips to secure the cable to the open cable guides on the frame.



2 REAR BRAKE The rear brake loops across the head tube and into the first cable stop on the downtube. The line is run along the downtube in the second and third open cable stops. Then the line attaches to the stops on the top-side of the chainstay. At this point the brake line is swung to the inside of the chainstay and looped up to the caliber body.



HOUSING END CAPS Yeti recommends using metal end caps to maintain the integrity of the housing. The metal caps do not allow the cable to pull through as do the plastic versions. Do not mix up the shift and brake housing because it will result in a loss in performance.

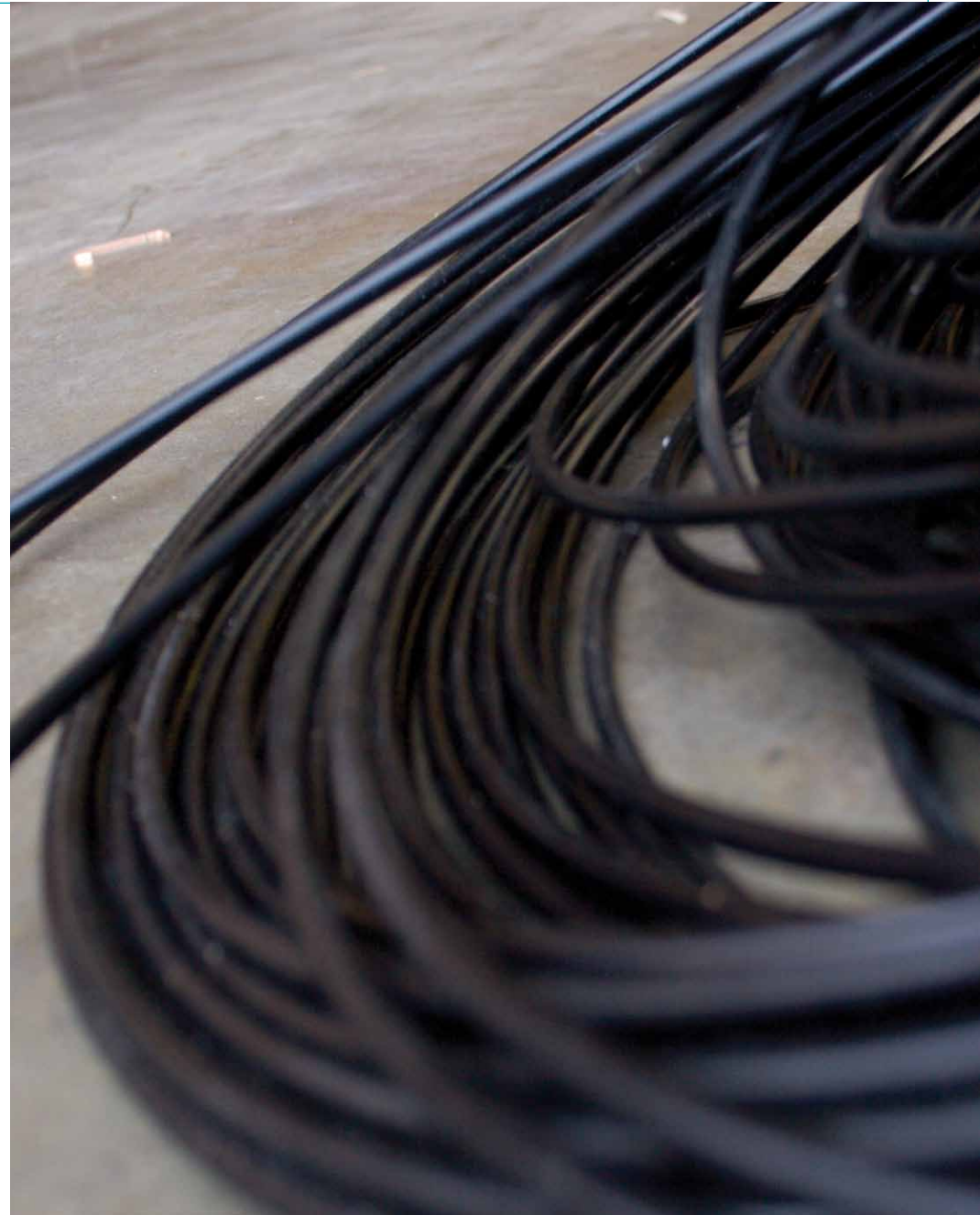

Assembly



TOOLS NEEDED

- Dead blow hammer
- Adjustable pliers
- Two - 5mm allen keys
- 6mm allen key
- 4mm allen key
- 4mm t-handle allen key
- 8mm allen key or 5/16 guide
- Linkage tool

TIME

30-45 minutes depending on condition of the bike

YETI TIPS

- Make sure your tools are in good condition. A worn allen key can round the hex on a bolt preventing proper torque. Be careful when using ballpoint allen wrenches for the same reason.
 - Torque settings are listed throughout the instructions. It is also important to prep all bolt threads. The instructions denote whether to use a blue Loctite compound or grease.
 - The linkage tool is necessary to properly disassemble and reassemble the linkage. Using a hammer to tap out the pin can cause damage to the linkage and shock.
 - Not every tool may be needed for the assembly / disassembly of your bike. The list encompasses all the tools necessary to completely assemble and disassemble a each bike.
- Warning:** Service on Yeti bicycles requires special knowledge and tools. Yeti Cycles recommends that all service and repairs be performed by an authorized Yeti dealer.



Assembly

1 DOGBONE & SHOCK SETUP Insert two double-row bearings with shoulders facing out into top of dogbone. Make sure bearings are flush on both sides of dogbone.

Tip: Shoulder is part of bearing that sticks out.



2 DOGBONE & SHOCK MOUNTING ASSEMBLY Take two M3 x .5 x 12mm pinch bolts and apply Loctite before fastening down the upper two bearings.



3 DOGBONE & SHOCK MOUNTING ASSEMBLY Now insert one double-row bearing with shoulders facing out to each side of the bottom of the dogbone. Take two M3 x .5 x 12mm pinch bolts and apply Loctite before fastening down the lower two bearings.

Tip: Do not overtighten the pinch bolts. This will cause pinching and binding.



4 DOGBONE & SHOCK MOUNTING ASSEMBLY Insert 22mm reducers into bottom of shock. Use dead blow hammer to pop into place.



THREAD PREP Yeti recommends prepping all bolt threads at once on your work bench with Loctite or grease. This will ensure that all bolts are used in assembly. The medium strength (blue) Loctite formula along with proper torque is ideal to keep the bolts snug.

5 REAR TRIANGLE ASSEMBLY Slide a 8.5mm ID washer onto the 31.0mm Ti female. Slide through front of shock and front tabs of frame.

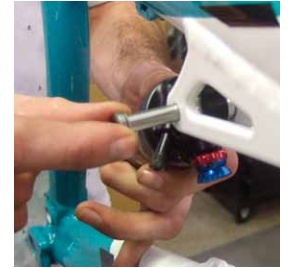

6 REAR TRIANGLE ASSEMBLY Tighten down with Ti male bolt and 2.5mm allen key.

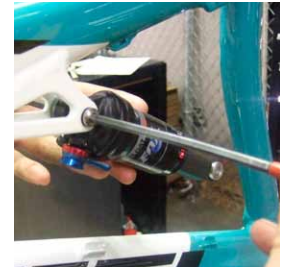

7 MOUNTING REAR TRIANGLE Attach dogbone to tabs on top tube with 31.0mm Ti female. Tighten down with a Ti male bolt and two 5mm allen keys.



8 MOUNTING REAR TRIANGLE Pull shock and dogbone together.



Assembly Cont.

9 MOUNTING REAR TRIANGLE Slide chainstay over indentions. Grease up main pivot pin (58.5mm long) and align with left finger. Hammer into place with dead blow hammer.



10 Using a 6mm and 5mm allen key, use a male bolt to tighten down male pivot with male bolt. Once you tighten down main pivot, tighten down pinch bolts on chainstay with 4mm allen key.



11 Make sure bearings on rear chainstay is flushed with metal of chainstay. Install seatstay with "Yeti" logo facing out above the dropout.



12 Slide a 8.5mm ID washer onto a Ti female 16.5mm and install to connect the seatstay and chainstay. Slide a 6.5mm ID washer onto a male bolt and screw into female bolt. Use 5mm key to tighten down.



Tip: Use an elbow 5mm allen key to give more room when tightening down.

13 Screw male bolt into Ti female stud. Slide a 8.5mm ID washer Ti female stud.



14 Pull seatstay together with dogbone and shock. Use Fox guide pin to align everything up. Insert guide pin through junction with dead blow hammer.



15 FINISHING TOUCHES Use dead blow hammer to hammer female stud through. Be ready to catch as it exits the non-drive side of the bike. Tighten down with 5mm allen keys.



16 Double-check pinch bolts on the dogbone and tighten down with 2.5mm allen key. Double-check tightness of all other bolts.



Disassembly Tips

1 FRAME DISASSEMBLY Use two 5mm allen keys to loosen Ti stud from male bolt at dogbone, shock and seatstay junction.



2 FRAME DISASSEMBLY Hammer in Fox guide pin with dead blow hammer. Be prepared to catch female bolt as it exits the non-drive side of the bike.

Tip: If there is any binding during the removal process, loosen up pinch bolts with a 2.5mm allen key.



3 FRAME DISASSEMBLY Drive the Fox guide pin the rest of the way out.

Tip: If needed use a 6mm allen wrench to help pin the rest of the way out.



4 FRAME DISASSEMBLY Slide seatstays down and back off Ti female stud and male bolts with 6mm allen key in-between the seatstay and chainstay.

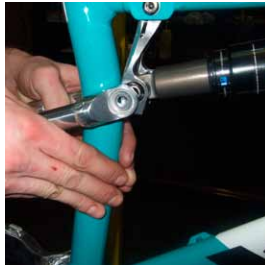

5 FRAME DISASSEMBLY Use 6mm elbow allen key to take out the 16.5mm female bolt. At the same time, make sure to hold onto the seatstay so it does not fall.



6 FRAME DISASSEMBLY Loosen up the male bolt from the main pivot. Stand against the drive side of the bike, and use punch to drive out main pivot.

Tip: If binding, loosen pinch bolts on main pivot bearings.



7 FRAME DISASSEMBLY Slide chainstay off of rear indentions. Separate dogbone and shock.



8 FRAME DISASSEMBLY Take 2mm allen key and back off Ti male and female bolt from dogbone. Repeat same step for shock.

Tip: Be careful when removing shock to prevent paint blims in the downtube.



CHANGES We strive to make the best bikes in the world. Because of this dedication, we continually make changes to our bikes as needed. As the bikes are improved, assembly and setup instructions may be affected. Any amendments to the existing Owner's Manual can be found on our website at www.yeticycles.com.

Exploded Views

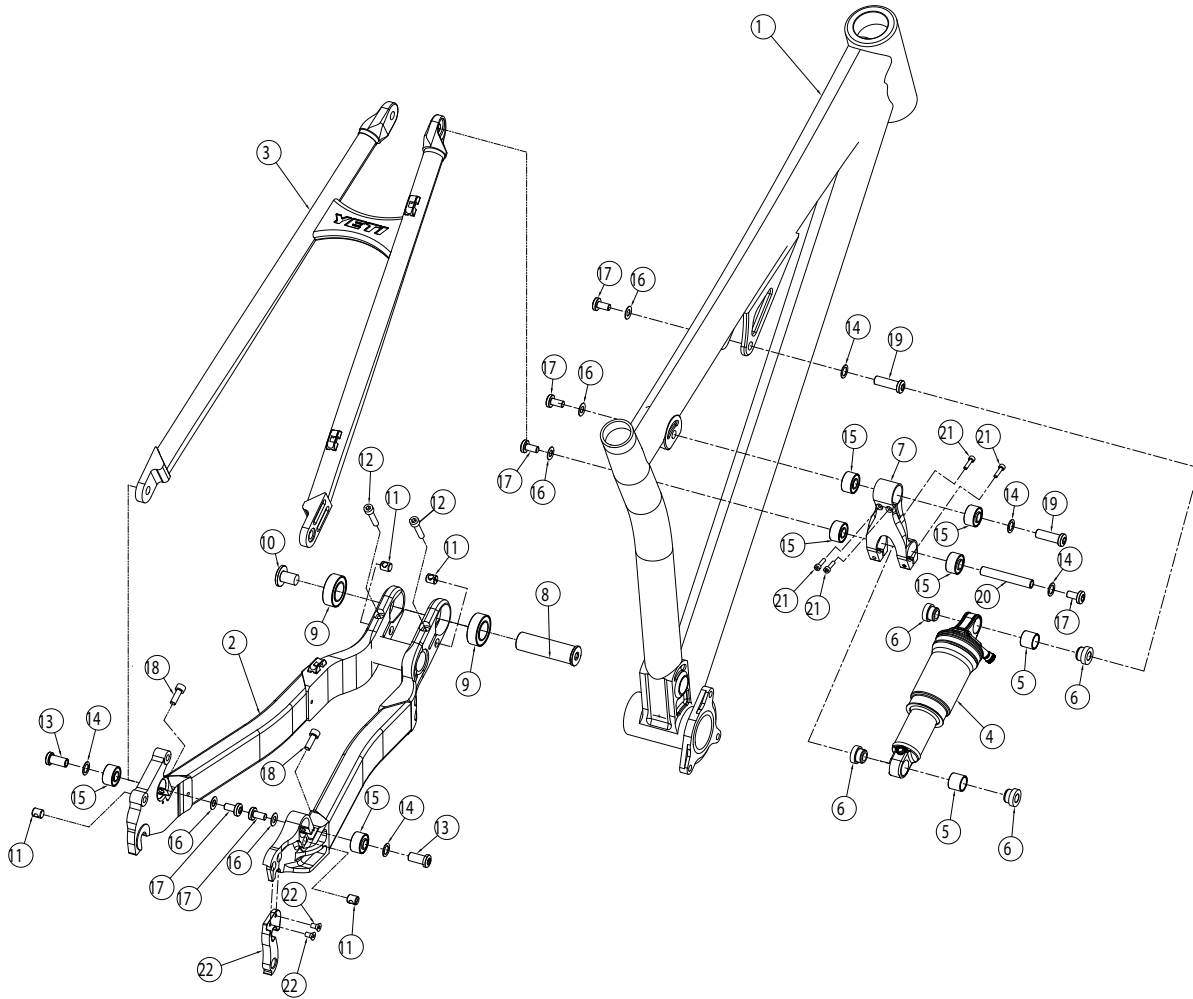

REBUILD KITS The individual components of each Yeti bike are not sold separately. All Yeti parts are sold in rebuild kits listed below. Each and every part can be obtained by purchasing one of the rebuild kits. Cross reference the part number you desire from the parts lists.

PARTS LIST W/FOX SHOCK

QTY.	PART #	DESCRIPTION
1	1	NA Front Triangle
2	1	NA Chainstay - 4X - Painted - 8
3	1	NA Seatstay - 4X - Painted - 8
4	1	NA Rear Shock - Fox RP23
5	2	300020020 Fox Garlock
6	4	300020034 Reducer - 22mm (Front/Rear)
7	1	300040228 Dogbone - 4X
8	1	300030194 Pivot Pin (M10 x 17 x 58.5mm)
9	2	300020030 Bearing 3903 2RS Double Row
10	1	300030189 Pivot Pin Bolt (M10)
11	4	300040349 Barrel Insert (M5)
12	2	300030196 Bolt Cap M5 x 0.8 x 24mm
13	2	300030114 Bolt - Ti - Female (M6 x 8 x 16.5mm)
14	5	300030069 Washer (8.5 x 12.5 x 0.5mm)
15	6	300020032 Bearing 398 2RS MAX Double Row
16	5	300030062 Washer (6.5 x 12.5 x 0.5mm)
17	6	300030110 Bolt - Ti - Male (M6 x 1 x 12mm)
18	2	300030010 Bolt Cap M5 x 0.8 x 16mm
19	2	300030186 Bolt - Ti - Female (M6 x 31mm)
20	1	300030187 Stud - Ti - Female (M6 x 8 x 53mm)
21	4	300030056 Bolt Cap M3 x 0.5 x 12mm
22	1	300060045 Derailleur Hanger w/ Fastners

Parts List

PART NUMBER	DESCRIPTION	QTY.
200020097	4X '06-'11 MASTER REBUILD KIT	1
300020030	BEARING 3903 2RS DOUBLE ROW	2
300020032	BEARING 398 2RS MAX DBL ROW	6
300030056	BOLT CAP M3X0.5X12	4
300030114	BOLT-TI-FEMALE 8X16.5MM	2
300030110	BOLT-TI-MALE M6X1 12MM	5
300030077	PIVOT BOLT FEMALE YETI 24.8MM	2
300030078	PIVOT BOLT MALE YETI 17MM	2
300030115	PIVOT PIN - AL - 17MMX58.5MM	1
300020034	REDUCER FOX 8X22MM	2
300030187	STUD-TI-FEMALE 8X53MM-SOLID	1
300030062	WASHER SS 6.5MM ID 12.5 OD .5M	3
300030069	WASHER SS 8.5MM ID 12.5MM OD .	7
300030179	WASHER-CUSTOM PIVOT PIN-7075	1
200020098	4X '06-'11 BEARING REBUILD KIT	1
300020030	BEARING 3903 2RS DOUBLE ROW	2
300020032	BEARING 398 2RS MAX DBL ROW	6
200020117	4X '06-'11 HARDWARE KIT	1
300030110	BOLT-TI-MALE M6X1 12MM	2
300030077	PIVOT BOLT FEMALE YETI 24.8MM	2
300030078	PIVOT BOLT MALE YETI 17MM	2
300030187	STUD-TI-FEMALE 8X53MM-SOLID	1
300030062	WASHER SS 6.5MM ID 12.5 OD .5M	3
300030069	WASHER SS 8.5MM ID 12.5MM OD .	7

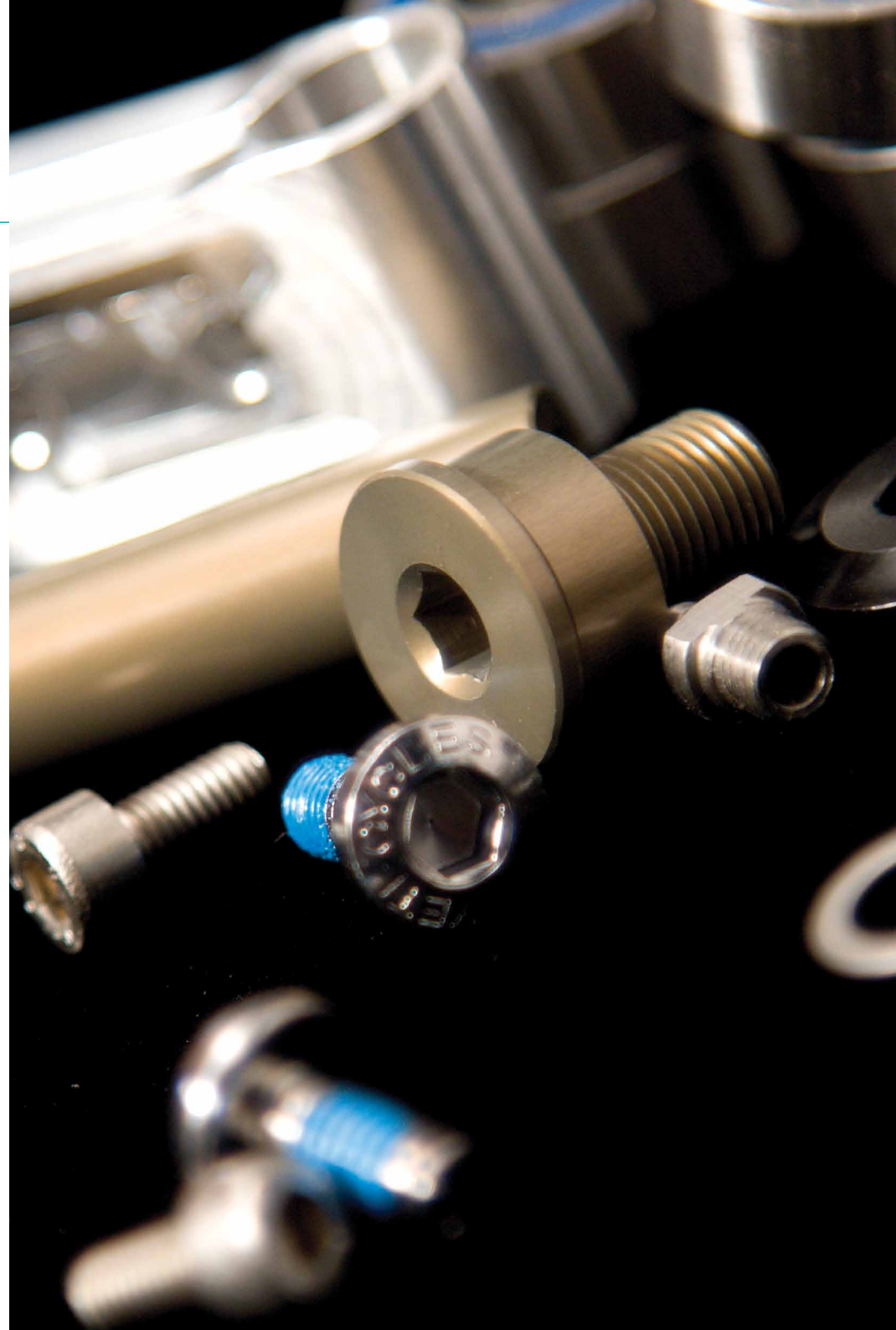

Warranty

YETI LIMITED (2) TWO YEAR FRAME WARRANTY (applies to 303 DH, 303 RDH, 25TH 303 DH, AS-R 7 > 160MM Fork, DH-9, AS-X, 4X, DJ, SX)

Yeti Cycles will repair or replace, at its option, any frame it determines to be defective materials and / or workmanship. The (2) two year limited warranty is conditioned upon the bicycle being ridden under normal conditions and having been properly maintained. This warranty does not apply to the components attached to the frameset such as suspension components, wheels, drive train, brakes, seatpost, handlebar and stem. This warranty applies only to the original owner and is non-transferable. This warranty is void if the bicycle was not properly assembled by an authorized Yeti dealer.

YETI LIMITED (5) FIVE YEAR FRAME WARRANTY (applies to AS-R 5 Carbon, AS-R 5 Alloy, AS-R Carbon, AS-R Alloy, AS-R-sllc), AS-R, AS-R 7 w/160MM Fork, 575, ARC, ARC-X, Big Top 29'R, FRO, Kokopelli)

Yeti Cycles will repair or replace, at its option, any frame it determines to be defective materials and / or workmanship. The (5) five year limited warranty is conditioned upon the bicycle being ridden under normal conditions and having been properly maintained. This warranty does not apply to the components attached to the frameset such as suspension components, wheels, drive train, brakes, seatpost, handlebar and stem. This warranty applies only to the original owner and is non-transferable. This warranty is void if the bicycle was not properly assembled by an authorized Yeti dealer.

ADDITIONAL CONDITIONS

These limited warranties do not apply to normal wear and tear, nor to claimed defects, malfunction or failures that result from abuse, neglect, improper assembly, improper maintenance, alteration, collision, crash or misuse. The original owner shall pay all labor charges connected with the repair or removal of all components. Under no circumstances does this limited warranty include of the cost of travel or shipment to and from an authorized Yeti dealer. In order to exercise your rights under these limited warranties, the bicycle or frameset must be presented to an authorized Yeti dealer, together with proof of purchase.

- The above warranties have been in effect since January 2000. All Yeti frames sold prior to that date had a limited (1) one year warranty on the frameset.
- No Fault Replacement Policy
- Yeti Cycles will make replacement parts available at a minimum charge to the original owner in the event of a crash or any other non-warranty situation. Yeti Cycles does this at its sole discretion and reserves the right to refuse this offer.
- If you have a warranty concern, please contact your authorized Yeti dealer.

NO FAULT REPLACEMENT POLICY

Yeti Cycles will make replacement parts available at a minimum charge to the original owner in the event of a crash or any other non-warranty situation. Yeti Cycles does this at its sole discretion and reserve the right to refuse this offer. If you have a warranty concern, please contact you authorized Yeti dealer.

PRODUCT LIFE CYCLE

Every Yeti frameset has a useful product life cycle. The length of that useful product life cycle will vary depending on the construction and materials of the frameset, maintenance and care the frameset receives, and the amount and type of use the frameset is subjected to over its life. Yeti recommends that an authorized Yeti dealer should inspect the frame for stress annually. Frame stress could cause potential failure and the signs are usually apparent in the form of cracks, fracture lines, deformation, dents and other visual indicators of abnormality. These safety checks for frame stress are important to prevent accidents, injury to the cyclist

and product failure of a Yeti frameset.

DISCLAIMER

Yeti Cycles is not responsible for any damages to you or others arising from riding, transporting or other use of your bicycle. In the event that your frame breaks or malfunctions, Yeti Cycles shall have no liability or obligation beyond the repair or replacement of your frame pursuant to the terms outline in this warranty.

CONTACT INFO

Yeti Cycles
600 Corporate Circle, Unit D
Golden, CO 80401
(p) 303-278-6909
(f) 303-278-6906
WWW.YETICYCLES.COM

BUSINESS HOURS

Monday-Friday
8AM-11:30AM, 1:00PM-5:30PM
(Mountain Time)