

**RIDE  
DRIVEN  
YETI SINCE 1985  
CYCLES**

**YETICYCLES.COM**

**RIDE  
DRIVEN  
YETI SINCE 1985  
CYCLES**

**2011 AS-R 5 OWNER'S MANUAL**

# Table of Contents

Brand Overview	6
Frame Features	8
Geometry	10
Maintenance Schedule	12
Shock Setup Fox RP23	14
Cable/Line Setup	16
Assembly Overview	18
– Assembly	20
– Disassembly Tips	23
Chip System	24
Exploded Views	26
Part List	28
Warranty	30
Contact Information	31

# Overview

## WELCOME TO THE TRIBE

Congratulations on your purchase of a new Yeti bicycle and welcome to the Yeti Tribe. We are confident your new bicycle will exceed your expectations for value, performance and ride quality. Each frameset and component has been custom specified and designed to enhance your riding experience. Whether you are a beginner cyclist or a seasoned-pro, Yeti bicycles will provide endless hours of two-wheeled fun.

## GENERAL INFORMATION

This model-specific manual is designed to be used in conjunction with the general Yeti Owner's Manual and the manuals supplied by the suspension manufacturers. If you did not receive the Yeti Owner's Manual or the manual provided by the suspension manufacturer, download the materials off the Internet, or contact your dealer.

Bicycling can be a hazardous activity even under the best of circumstances. Proper maintenance of your bicycle is your responsibility and when done properly helps reduce the risk of injury and damage to your bicycle. This manual outlines basic setup and maintenance recommendations of your new Yeti. Because it is impossible to anticipate every situation or condition that may occur during the assembly, setup and maintenance of your bicycle,

Yeti recommends that all service and repairs be performed by an authorized Yeti dealer.

This manual contains many "Warnings" and "Cautions" concerning the consequences of failure to maintain or inspect your bicycle. The combination of the safety alert symbol and the word "Warning" indicates a potentially hazardous situation in which, if not avoided, could result in serious injury or death. The combination of the safety alert symbol and the word "Caution" indicates a potentially hazardous situation in which, if not avoided, may result in minor injuries or damage to your bicycle or a component of your bicycle. Be sure to read and understand all "Warnings" and "Cautions".



**Warning:** Make sure you review and understand the warnings, instructions and content of this manual and accompanying manuals for your bicycle.



**Warning:** Technological advances have made bicycles and bicycle components more complex and the pace of innovation is increasing. It is impossible for this manual or accompanying manuals to provide all the information required to properly repair and maintain your bicycle. In order to help minimize the chances of injury, it is critical for you to have work performed by an authorized Yeti dealer.



# Frame Features

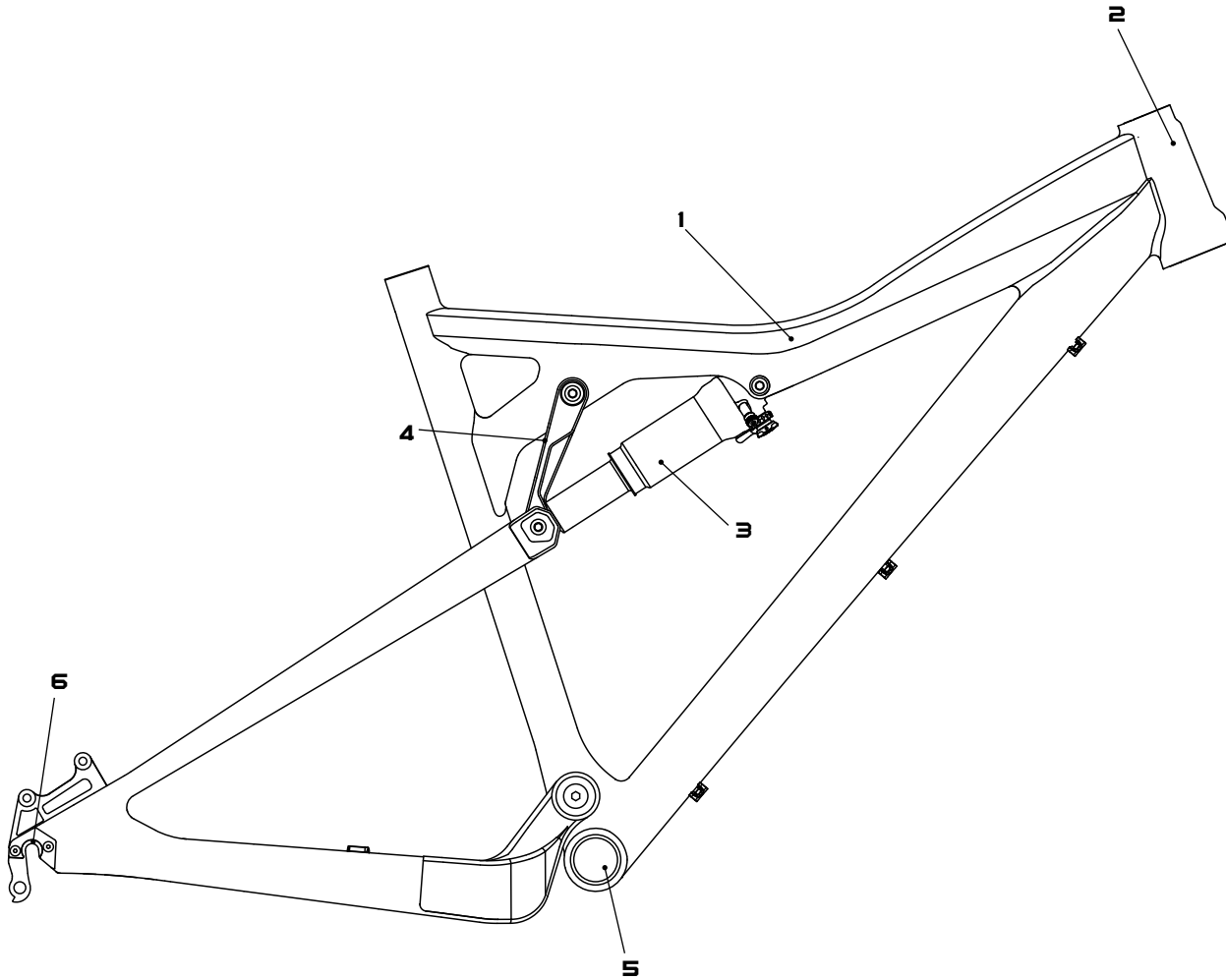

1. **FULL CARBON FRAME**

The front and rear triangles are constructed entirely of high modulus, hand laid-up carbon with co-molded aluminum lugs at the bearing and pivot connections.

2. **TAPERED HEADTUBE**

The AS-R 5 has a tapered head tube. The bottom cup is 1 - 1/2" and the top cup is 1-1/8". This creates a very stiff front end in combination with a tapered fork without adding additional weight.

3. **SHOCK**

7.875" eye-to-eye / 2" stroke.

4. **ALLOY DOGBONE**

The dogbone here at Yeti is an integral part of our suspension design. Structurally, the Dogbone significantly reduces side to side flex of the frames swingarm. Additionally, it prevents any side loading on the rear shock. This is important as to not limit the performance or life of the rear shock. With any design, the shock should not be depended on for structural support.

5. **BOTTOM BRACKET**

73mm bottom bracket shell

6. **DROPOUTS**

The AS-R 5 utilizes a chip system for the rear dropouts allowing you to change out the drops based on the rear wheel sizing you are running. The chip system allow for a standard 135mm \* 10mm QR or the new 142mm \* 12mm axle.

# Geometry

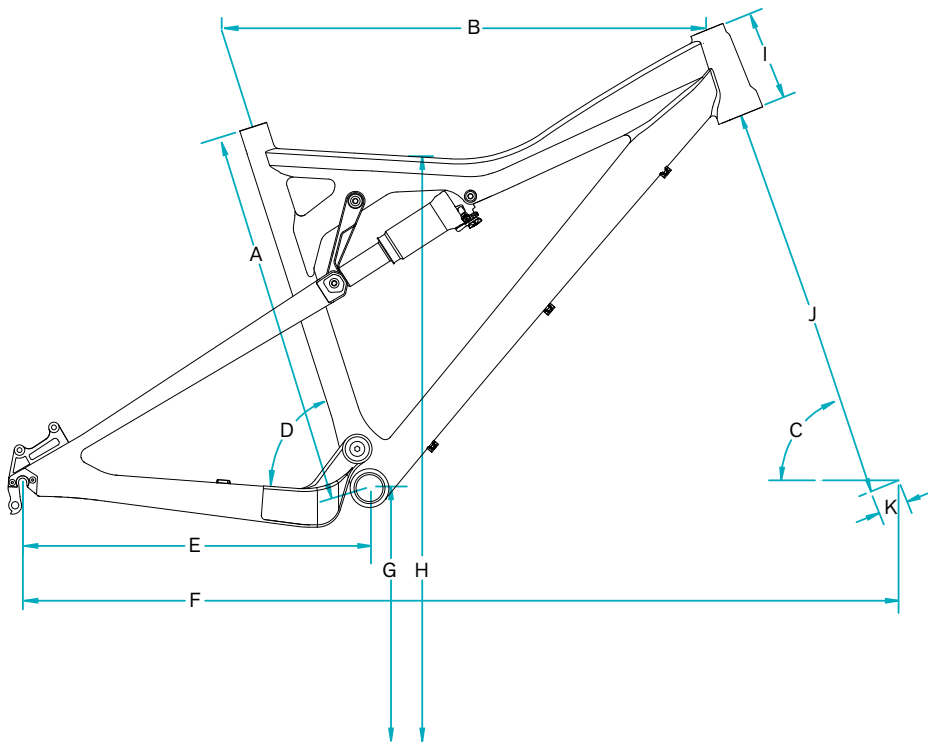

## GEOMETRY AS-R 5 CARBON

### 140 MM FORK

	SM	MD	LG
A	17.5	18.5	20.5
B	22.7	23.7	24.7
C	67.0	67.0	67.0
D	71.2	71.2	71.2
E	16.9	16.9	16.9
F	43.2	44.2	45.2
G	13.3	13.3	13.3
H	29.3	29.3	29.5
I	4.50	4.50	5.10
J	19.35	19.35	19.35
K	1.55	1.55	1.55

### 120 MM FORK

	SM	MD	LG
A	17.5	18.5	20.5
B	22.5	23.6	24.6
C	68.0	68.0	68.0
D	71.2	71.2	71.2
E	16.9	16.9	16.9
F	42.9	43.9	44.9
G	13.0	13.0	13.0
H	28.9	28.9	29.1
I	4.50	4.50	5.10
J	21.45	21.45	21.45
K	1.55	1.55	1.55

\*All measurements are in inches.

# Maintenance

**MAINTENANCE** Following these guidelines will help maintain the performance of your bicycle and prevent more serious problems from arising. It is important to remember that service intervals can vary depending on climate, trail conditions and riding frequency.

ACTION	WEEKLY	MONTHLY	3 MONTHS	ANNUALLY
Clean and lube chain	x			
Check tire pressure	x			
Clean bike of mud and debris (never spray water directly into frame or components)	x			
Check brake function	x			
Check shock pressure, if applicable	x			
Check for loose bolts and tighten, if necessary		x		
Check headset and tighten / loosen, if necessary		x		
Thoroughly clean pivot points with a rag (do not lubricate)		x		
Replace brake pads, if necessary			x	
Check tires for wear			x	
Check spoke tension and retention, if necessary			x	
Check chain for worn, damaged, or loose links, replace chain if necessary			x	
Complete tune-up performed by an authorized Yeti dealer				x



**MAINTENANCE?** If you are having trouble with any of the maintenance tasks that need to be performed contact your local dealer or visit [www.parktool.com](http://www.parktool.com) and check out the repair help section. This section contains detailed instruction on many of the service items listed in the maintenance schedule.

**TORQUE** We have attached a brief list of torque specifications for bolts and components that may need to be tightened while performing basic maintenance. This is just a guide. For specific torque, specifications, please contact the component manufacturer directly.

## TORQUE SPECS

Pivot Bolts	125 - 150
Derailleur Hanger Bolts	30 - 45
Handlebar Binder Bolt	150 - 180
Stem Binder Bolt	175 - 260
Seatpost Binder Bolt	150 - 180
Saddle Clamp Bolts	175 - 250
Rear Derailleur	70 - 86
Front Derailleur Clamp	45 - 60
Chainring Bolts	88 - 132



**Caution:** The torque specifications listed should be used as a guide when performing maintenance. Technological advances have made bicycles and bicycle components more complex, and the pace of innovation is increasing. Because of these advances, Yeti recommends that you refer to the torque specifications of the manufacture's component you are adjusting. In order to help minimize the chances of injury, do not perform any maintenance that you are no confident can be completed within your abilities.

# Setup-Fox RP23

# Quick Start Guide

**1 AIR PRESSURE** The main air spring controls the sag of the shock. For the AS-R 5 to ride properly it is important to setup the shock with the correct amount of sag. For general riding use 20-30% of the shock stroke (5mm to 10mm). To increase sag reduce the main spring air pressure. To reduce sag increase the main spring air pressure. Refer to the quick start guide to get your starting air pressure.

**Firm ride- 20-25% sag**  
**Plush ride- 30% sag**

**2 SAG** Once you have set your baseline air pressure you need to measure the sag. To measure the sag slide the travel indicator (O-Ring) up against the shock body. With a friend supporting the bike, sit on the saddle and allow your body weight to compress the shock. Once you have compressed the shock, get off the bike and measure the distance between the shock body and the new position of the travel indicator (O-Ring). This is your sag. Refer to the guide below for the percentage of sag equivalents for the measurement recorded.

**3 PRO-PEDAL** The pro-pedal damping has three levels of adjustment and is controlled by the blue lever (formerly the lock-out lever). The three different levels of damping are light, medium and heavy pro-pedal.

We recommend setting the pro-pedal in the middle of its adjustment range (position 1). If you feel like the bike is too firm and is not absorbing the small bumps, flick the lever left to the light setting. If the bike feels sluggish and you want the suspension to feel more efficient, turn the lever right to the stiffer setting.

**4 REBOUND** The rebound adjustment has a nine-click range. The rebound knob is the red adjustment dial located above your blue pro-pedal adjustment lever. As a general rule, adjustments that are too fast (counter-clockwise adjustment) will produce a springy ride with excessive kick-up of the rear end causing a bucking sensation. Adjustments that are too slow (clockwise adjustment) will cause packing of the rear wheel indicated by a sluggish ride feeling ride.

**Slower rebound - turn the knob clockwise**  
**Faster rebound- turn the knob counter-clockwise**



## QUICK START GUIDE RP23 AS-R 5 CARBON

### AIR SPRING SETTINGS

Rider Weight lbs	120	130	140	150	160	170	180	190	200	210
Air Pressure (psi)	110	120	130	140	150	160	170	180	190	190

### SAG SETTINGS

Sag %	20	25	30
Measured (inches)	.300	.375	.400

### \*EXTERNAL ADJUSTMENTS

Rebound	5 Clicks
Pro-Pedal Lever	On // Active
Pro-Pedal Knob	Position 1

\*All quick start setting adjustments are clockwise rotation from all the way out or a full counter-clockwise position.



**WHAT IS PRO-PEDAL?** Pro-pedal is a compression tune that gives the right amount of low-speed compression to filter out unwanted rider-induced bob without sacrificing critical mid- and high-speed damping. No flushing through your travel, no wasted setup time, and no energy-sucking suspension movement. Just super efficient pedaling performance ready for hits of any size.

## Line Setup

The AS-R 5 has full cable housing. By using full cable housing, we have eliminated break points in the line of your shifter housing. This allows riders to experience better overall shifting performance by reducing the entrance of unwanted elements such as sweat and sediment. Use of full cable housing helps prevent corrosion from the elements and keeps the shifting smoother for a longer period of time.

**Caution:** The failure to properly route shifter housing can cause malfunction of the shift mechanism and unexpected shifting of gears.

**1 REAR DERAILLEUR** Fit the housing from the rear shifter along the drive side of the head tube and down the cable stops. There are three bolt-on cable stop on the down tube to which the housing and brake lines are attached, each with three separate positions. Fit the housing line along the down tube into these stops, using the position closest to the drive side.



Next route the housing under the bottom bracket and through the drive side chainstay and loop onto the derailleur. Run the housing through the hole on the chainstay and push it through the exit hole by the rear derailleur. Remove the cap on the exit side of the chainstay to make this process easier. Ensure to leave enough "slack" between the last cable stop on the down tube and the chainstay to allow for smooth shifting when the rear suspension is being compressed.

**2 FRONT DERAILLEUR** Fit a piece of housing from the front shifter across the head tube and down the three bolt-on cable stop groups on the down tube. Use the middle position on the cable guides for the front derailleur housing.



Next route the housing into the cable stop on the bottom bracket shell. The wire cable will run through the cable stop and then attach to the front derailleur.

**3 REAR BRAKE** The rear brake line loops across the head tube and into the bolt-on cable stops on the down tube. Use the position closest to the non-drive side on the cable guides for the rear brake line.

Next route the brake line over the bottom bracket shell and across the non drive chainstay. Use the single bolt-on cable guide on the chain stay to secure the line. Ensure the line is finished on the inside of the seatstay when attached to the caliper body. This will prevent the brake line from being compromised if the bike or rider falls.

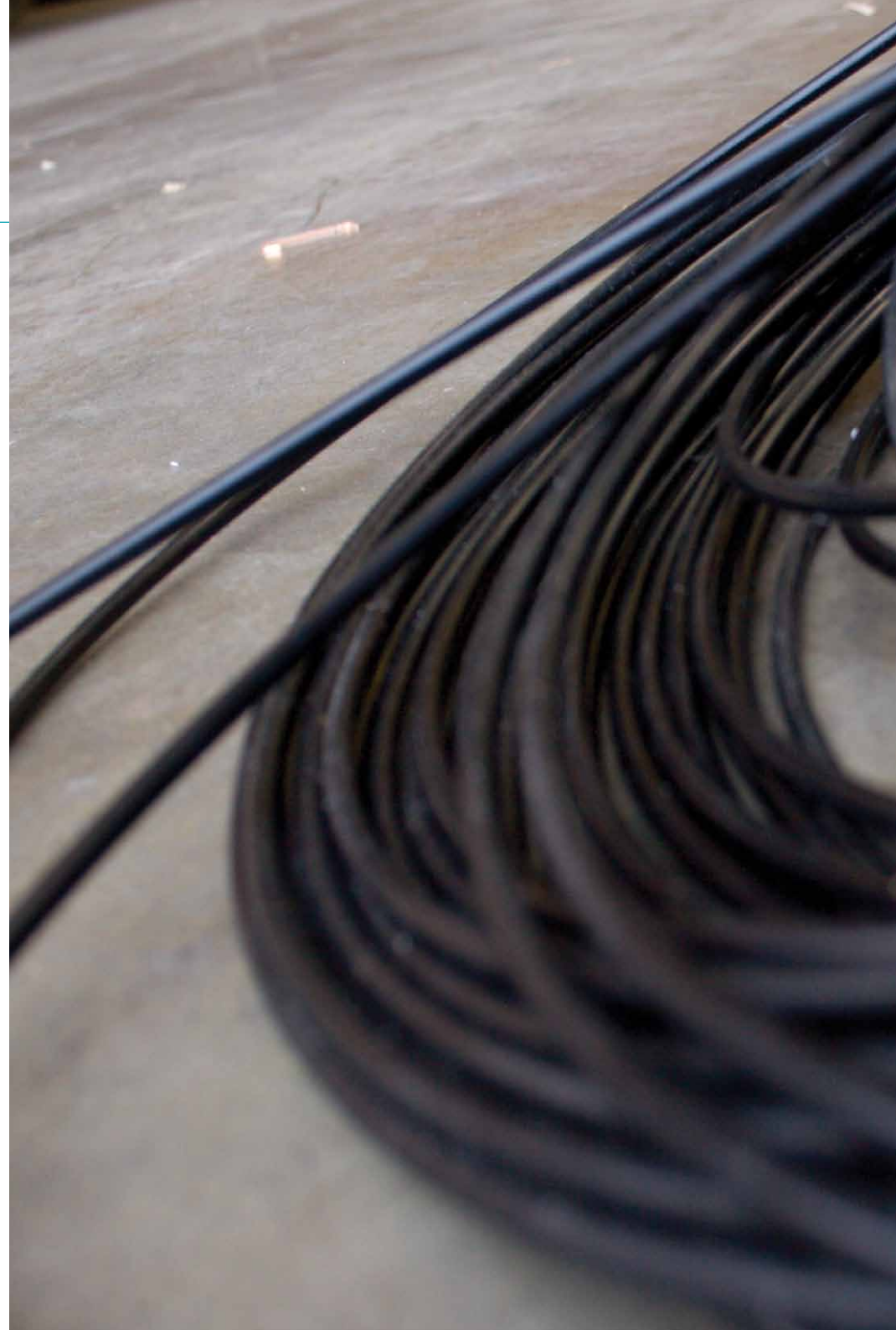



# Assembly



## TOOLS NEEDED

- Dead blow hammer
- Two - 5mm allen keys
- 6mm allen key
- 2.5mm allen key
- Guide Pin Tool

## TIME

30-45 minutes depending on condition of the bike

## YETI TIPS

- Make sure your tools are in good condition. A worn allen key can round the hex on a bolt preventing proper torque. Be careful when using ballpoint allen wrenches for the same reason.
- Torque settings are listed throughout the instructions. It is also important to prep all bolt threads. The instructions denote whether to use a blue Loctite compound or grease.
- Not every tool may be needed for the assembly / disassembly of your bike. The list encompasses all the tools necessary to completely assemble and disassemble a each bike.



**Warning:** Service on Yeti bicycles requires special knowledge and tools. Yeti Cycles recommends that all service and repairs be performed by an authorized Yeti dealer.



# Assembly

**1 DOG & SHOCK MOUNTING ASSEMBLY** Press bearings flush into the bottom of the dogbone with shoulder facing out. Place a spacer between the bearings while installing to ensure the dogbone is not bent or damaged.

Repeat for top of dogbone with shoulders of bearings facing in. A spacer is not necessary for this step.



**2 DOG & SHOCK MOUNTING ASSEMBLY** Use a dead blow hammer to install two 23.5mm reducers into the lower portion of the shock.



**3 DOG & SHOCK MOUNTING ASSEMBLY** Push the shock into the lower portion of the dogbone.



**4 DOG & SHOCK MOUNTING ASSEMBLY** Install the shock and dogbone on the frame. Insert a 31.0 mm Ti female bolt (use a 34.0 mm female bolt for the ASR5C) through the drive side of the frame for the shock. Use a Ti male bolt on the non-drive to tighten the shock into place with a 5mm allen key. Support the bottom of the assembly while tightening the shock to the frame.

**Tip:** Refer to torque specifications when working with Ti assembly bolts. Over tightening Ti bolts may result in fractures and damage.



**THREAD PREP** Yeti recommends prepping all threads with Loctite or grease. The medium strength (blue) formula along with proper torque is ideal for keep the bolts snug.

**5 REAR TRIANGLE ASSEMBLY** Install the dogbone using a 40.5mm Ti female bolt and a Ti male bolt. Orient the dogbone so the Yeti logo is facing the front of the frame, and use a dead blow hammer to insert 40.5mm female bolt through the top of the dogbone and the frame. Use the Ti male bolt on the non-drive side to tighten the dogbone into place with a 5mm allen key.

**Tip:** Use the fox guide pin tool and a dead blow hammer to help guide any female Ti bolts through frames and frame components.



**6 REAR TRIANGLE ASSEMBLY** Slide the swingarm over the main pivot bore, using the grooves in the swingarm to properly align over the bore.



**7 MOUNTING REAR TRIANGLE** Use the fox guide pin to align and hold the seatstays, dogbone, and shock together. Use a dead blow hammer to push the pin through the above mentioned components.



**8 MOUNTING REAR TRIANGLE** Install the main pivot pin (female) from the drive side of the bike. Use a dead blow hammer to push the pin into place.

Once the female pivot pin is in place, install and tighten the male pivot bolt with a 5mm allen key.

**Tip:** While installing the female main pivot pin, align the swingarm with the main pivot bore in the front triangle with your free index finger. Use grease on the threads of the male bolt and on the outside of the female pin. This will help prevent binding, seizing, or stripping over time.



## Assembly Cont.

**9 MOUNTING REAR TRIANGLE** Place a 46.5mm Ti female bolt over the male portion of the Fox guide pin. Use a dead blow hammer to push the bolt into place. Be prepared to catch the guide pin as it exits the non-drive side of the bike. Install and tighten a Ti-male bolt to the 46.5 female bolt with a 5mm allen key. Check the alignment of the swingarm, dogbone, and shock.



**10 FRAME ASSEMBLY** Double check alignment of all frame components and refer to the torque settings chart to ensure all bolts are properly tightened on frame.



## Disassembly Tips

**1 REAR TRIANGLE DISASSEMBLY** At the seatstay junction, remove the Ti male bolt from the 46.5 female bolt with a 5mm allen key.



**2 REAR TRIANGLE DISASSEMBLY** Insert the guide pin tool into the 46.5 female bolt and use a dead blow hammer to tap the bolt out of the frame. Be prepared to catch the bolt as it exits the drive side of the frame. Leave the guide pin in the frame during the next step.



**3 SHOCK & DOGBONE DISASSEMBLY** Remove the male main pivot bolt from the female main pivot pin with a 5mm allen key. Use a punch and a dead blow hammer to remove the main pivot pin from the swingarm and front triangle.

**Tip:** Brace the front triangle of the frame with your body while removing the main pivot pin. This will help prevent any damage to the front triangle and swingarm, and will allow for easier removal of the pin.



**4 SHOCK & DOGBONE DISASSEMBLY** Remove the guide pin from the seatstay junction and then pull the rear triangle off of the frame. Remove the male bolt from the 40.5mm Ti female bolt holding the dogbone in place. Use the guide pin and a dead blow hammer to tap the female bolt out of the frame. Repeat the process for the bolts holding the shock in place.





# Chip System

The 2011 AS-R 5 Carbon features our Yeti Chip System that allows for the use of a standard 135mm QR or a 12mm x 142mm thru axle. Based on your wheel and hub choices, simply insert the appropriate chips and you are on your way.

**1 REMOVING STOCK CHIP SET** Use a 2.5mm allen key to loosen the two M4x9mm flat head bolts holding the QR insert derailleur hanger in place. Remove the bolts and the QR insert from the frame. Repeat the process for the bolts and the non drive QR insert.



**2 INSTALLING DT DROPOUT KIT** Fit the 12MM insert derailleur hanger into the groove on the inside of the drive side chainstay. The hanger should be flush with the chainstay. Next, insert the threaded 12mm cap through the chainstay and into the hanger from the outside of the drive side chainstay. To finish, use a 3MM allen key to attach the two dropout pieces to the swingarm with two M4x15MM cap bolts. Prep the bolts with locktite and insert them into the threaded cap, through the swingarm and into the derailleur hanger.



Torque: 15-20 in/lb

**3 INSTALLING DT DROPOUT KIT** Fit the 12MM non-drive insert into the groove on the inside of the non-drive side chainstay. The insert should be flush with the chainstay. Next, insert the un-threaded 12mm cap through the chainstay and into the insert from the outside of the non-drive side chainstay. To finish, use a 3MM allen key to attach the two dropout pieces to the swingarm with two M4x15MM cap bolts. Prep the bolts with locktite and insert them into the un-threaded cap, through the swingarm and into the insert.



**4 INSTALLING SHIMANO DROPOUT KIT** Fit the 12MM insert derailleur hanger into the groove on the inside of the drive side chainstay. The hanger should be flush with the chainstay. Next, insert the 12mm drive cap through the chainstay and into the hanger from the outside of the drive side chainstay. To finish, use a 3MM allen key to attach the two dropout pieces to the swingarm with two M4x15MM cap bolts. Prep the bolts with locktite and insert them into the drive cap, through the swingarm and into the derailleur hanger.



**5 INSTALLING SHIMANO DROPOUT KIT** Fit the 12MM non-drive insert into the groove on the inside of the non-drive side chainstay. The insert should be flush with the chainstay. Next, fit the non-drive 12mm cap through the chainstay and into the insert from the outside of the non-drive side chainstay. To finish, use a 2.5MM allen key to attach the two dropout pieces to the swingarm with two M4x10MM flat head bolts. Prep the bolts with locktite and insert them into the non-drive cap, through the swingarm and into the insert.



**6 INSTALLING SHIMANO DROPOUT KIT** Insert the M4x6MM custom cap bolt into the top of the drive cap. This bolt will be used to set the position of the Shimano 142x12MM axle. Refer to Shimano literature for exact instructions on axle operations.

Torque: 15-20 in/lb



# Exploded Views



**REBUILD KITS** The individual components of each Yeti bike are not sold separately. All Yeti parts are sold in rebuild kits listed below. Each and every part can be obtained by purchasing one of the rebuild kits. Cross reference the part number you desire from the parts list to the rebuild list.

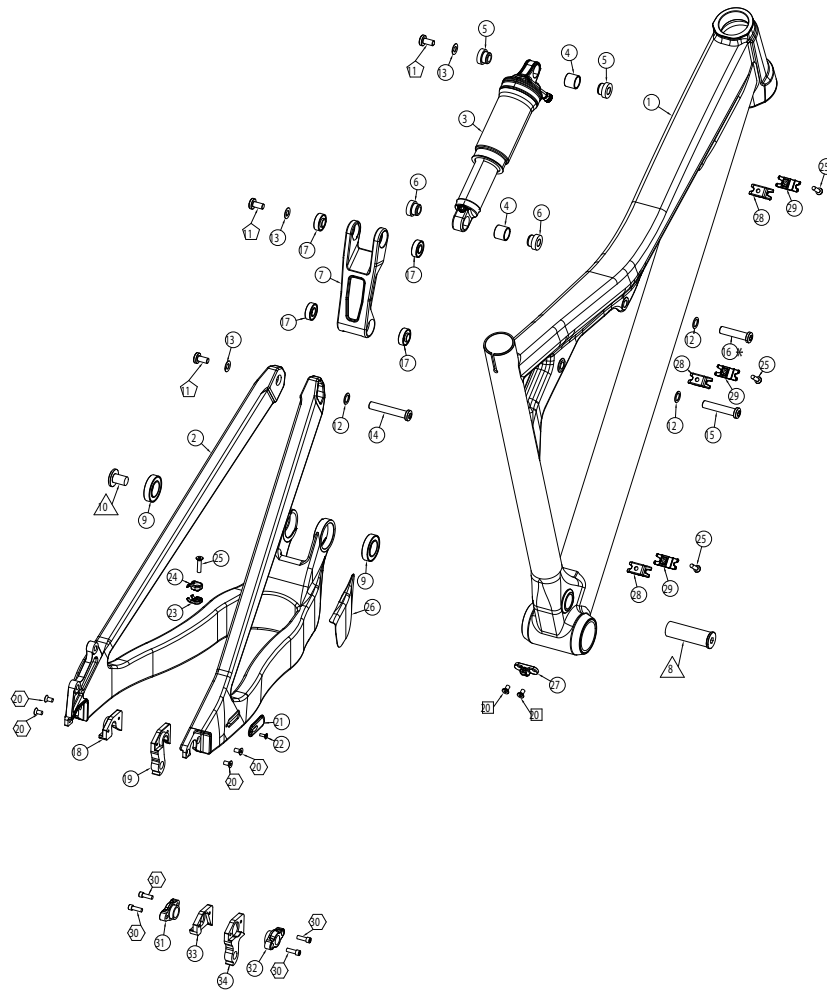

## PARTS LIST

DESCRIPTION	QTY
1 Front Tri (XS, SM, MD, LG, XL)	1
2 ASR-5 Swingarm	1
3 Fox RP23 Air (7.875 X 2 in)	1
4 "GARLOCK DU BUSHING .5" X .5"	2
5 REDUCER FOX 8X22MM	2
6 REDUCER FOX 8X23.5MM	2
7 ASR-5 Dogbone	1
8 PIVOT PIN 17X7.5/10X11THR D 52.4	1
9 BEARING 6903 MAX	2
10 PIVOT PIN BOLT M10 X 1 X 22	1
11 BOLT-TI-MALE M6X1 12MM	3
12 WASHER SS 8.5MM ID 12.5MM OD .	3
13 WASHER SS 6.5MM ID 12.5 OD .5M	3
14 BOLT-TI-FEMALE 8.0X46.5MM	1
15 BOLT TI FEMALE 8X40.5MM	1
16* BOLT-TI-FEMALE 8.0X31.0MM	1
16* BOLT-TI-FEMALE 8.0X34.0MM	1
17 BEARING 698MAX EXT RACE 1.5	4
18 QR INSERT NON-DRIVE	1
19 QR INSERT DER HANGER	1
20 BOLT FLAT HEAD M4X9MM	4
21 INTERNAL CABLE ROUTING CAP	1
22 BOLT FLAT HEAD M3X8MM	1
23 Bolt-On Cable Guide Single Bottom	1
24 Bolt-On Cable Guide Single Top	1
25 BOLT FLAT HEAD M4X16MM	4
26 Chain-Suck Protector	1

## PARTS LIST

DESCRIPTION	QTY
27 FRONT DER CABLE STOP	1
28 Bolt-On Cable Guide Triple Bottom	3
29 Bolt-On Cable Guide Triple Top	3
30 BOLT CAP M4X15MM	4
31 12mm CAP NON-DRIVE	1
32 12mm CAP DRIVE	1
33 12mm INSERT NON-DRIVE	1
34 12mm INSERT DER HANGER	1

\*Please note: This bolt length varies between the Carbon and Alloy Version (Alloy = 31mm, Carbon = 34mm)

# Parts List

PART NUMBER	DESCRIPTION	QTY.
200020173	ASR-5A AND ASR-5C BEARING REBUILD KIT	1
300020001	BEARING 6903 MAX	2
300020036	BEARING 698MAX EXT RACE 1.5	4
200020176	ASR-5 CARBON MASTER REBUILD KIT	1
300020001	BEARING 6903 MAX	2
300020036	BEARING 698MAX EXT RACE 1.5	4
300030190	BOLT TI FEMALE 8X40.5MM	1
300030111	BOLT-TI-FEMALE 8.0X34.0MM	1
300030112	BOLT-TI-FEMALE 8.0X46.5MM	1
300030110	BOLT-TI-MALE M6X1 12MM	3
300030188	PIVOT PIN 17X7.5/10X1THRD 52.4	1
300030189	PIVOT PIN BOLT M10 X 1 X 22	1
300020037	REDUCER FOX 8X23.5MM	2
300030062	WASHER SS 6.5MM ID 12.5 OD .5M	3
200020174	ASR-5 ALLOY MASTER REBUILD KIT	1
300020001	BEARING 6903 MAX	2
300020036	BEARING 698MAX EXT RACE 1.5	4
300030190	BOLT TI FEMALE 8X40.5MM	1
300030111	BOLT-TI-FEMALE 8.0X34.0MM	1
300030112	BOLT-TI-FEMALE 8.0X46.5MM	1
300030110	BOLT-TI-MALE M6X1 12MM	3
300030188	PIVOT PIN 17X7.5/10X1THRD 52.4	1
300030189	PIVOT PIN BOLT M10 X 1 X 22	1
300020037	REDUCER FOX 8X23.5MM	2
300030062	WASHER SS 6.5MM ID 12.5 OD .5M	3
200020177	ASR-5 CARBON HARWARE KIT	1
300030190	BOLT TI FEMALE 8X40.5MM	1
300030111	BOLT-TI-FEMALE 8.0X34.0MM	1
300030112	BOLT-TI-FEMALE 8.0X46.5MM	1
300030110	BOLT-TI-MALE M6X1 12MM	3
300030188	PIVOT PIN 17X7.5/10X1THRD 52.4	1
300030189	PIVOT PIN BOLT M10 X 1 X 22	1
200020175	ASR-5 ALLOY HARWARE KIT	1
300030190	BOLT TI FEMALE 8X40.5MM	1
300030186	BOLT-TI-FEMALE 8.0X31.0MM	1
300030112	BOLT-TI-FEMALE 8.0X46.5MM	1
300030110	BOLT-TI-MALE M6X1 12MM	3
300030188	PIVOT PIN 17X7.5/10X1THRD 52.4	1
300030189	PIVOT PIN BOLT M10 X 1 X 22	1

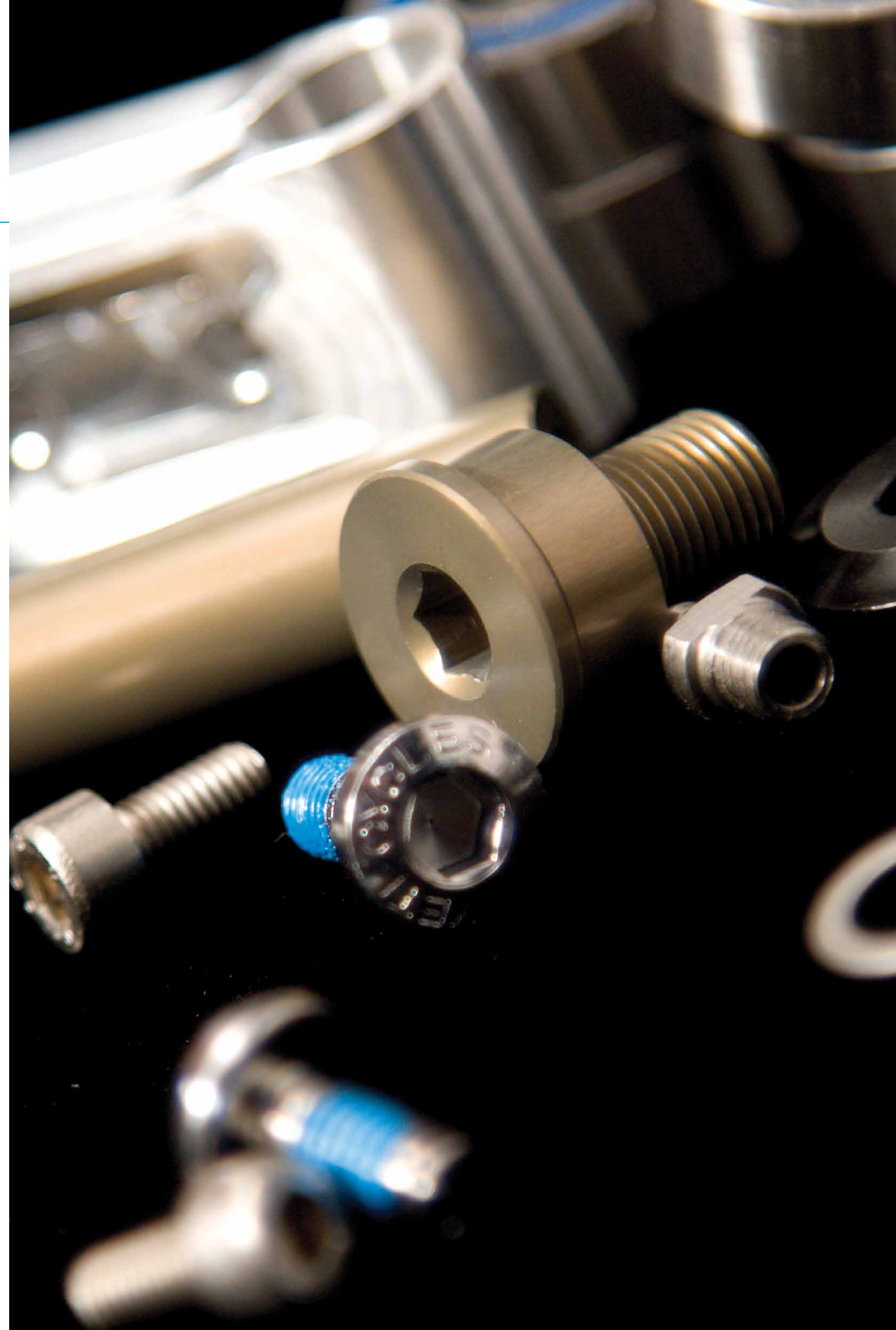

# Warranty

**YETI LIMITED (2) TWO YEAR FRAME WARRANTY** (applies to 303 DH, 303 RDH, 25TH 303 DH, AS-R 7 > 160MM Fork, DH-9, AS-X, 4X, DJ, SX)

Yeti Cycles will repair or replace, at its option, any frame it determines to be defective materials and / or workmanship. The (2) two year limited warranty is conditioned upon the bicycle being ridden under normal conditions and having been properly maintained. This warranty does not apply to the components attached to the frameset such as suspension components, wheels, drive train, brakes, seatpost, handlebar and stem. This warranty applies only to the original owner and is non-transferable. This warranty is void if the bicycle was not properly assembled by an authorized Yeti dealer.

**YETI LIMITED (5) FIVE YEAR FRAME WARRANTY** (applies to AS-R 5 Carbon, AS-R 5 Alloy, AS-R Carbon, AS-R Alloy, AS-R-sllc), AS-R, AS-R 7 w/160MM Fork, 575, ARC, ARC-X, Big Top 29"R, FRO, Kokopelli)

Yeti Cycles will repair or replace, at its option, any frame it determines to be defective materials and / or workmanship. The (5) five year limited warranty is conditioned upon the bicycle being ridden under normal conditions and having been properly maintained. This warranty does not apply to the components attached to the frameset such as suspension components, wheels, drive train, brakes, seatpost, handlebar and stem. This warranty applies only to the original owner and is non-transferable. This warranty is void if the bicycle was not properly assembled by an authorized Yeti dealer.

## ADDITIONAL CONDITIONS

These limited warranties do not apply to normal wear and tear, nor to claimed defects, malfunction or failures that result from abuse, neglect, improper assembly, improper maintenance, alteration, collision, crash or misuse. The original owner shall pay all labor charges connected with the repair or removal of all components. Under no circumstances does this limited warranty include of the cost of travel or shipment to and from an authorized Yeti dealer. In order to exercise your rights under these limited warranties, the bicycle or frameset must be presented to an authorized Yeti dealer, together with proof of purchase.

- The above warranties have been in effect since January 2000. All Yeti frames sold prior to that date had a limited (1) one year warranty on the frameset.
- No Fault Replacement Policy
- Yeti Cycles will make replacement parts available at a minimum charge to the original owner in the event of a crash or any other non-warranty situation. Yeti Cycles does this at its sole discretion and reserves the right to refuse this offer.
- If you have a warranty concern, please contact your authorized Yeti dealer.

## NO FAULT REPLACEMENT POLICY

Yeti Cycles will make replacement parts available at a minimum charge to the original owner in the event of a crash or any other non-warranty situation. Yeti Cycles does this at its sole discretion and reserve the right to refuse this offer. If you have a warranty concern, please contact you authorized Yeti dealer.

## PRODUCT LIFE CYCLE

Every Yeti frameset has a useful product life cycle. The length of that useful product life cycle will vary depending on the construction and materials of the frameset, maintenance and care the frameset receives, and the amount and type of use the frameset is subjected to over its life. Yeti recommends that an authorized Yeti dealer should inspect the frame for stress annually. Frame stress could cause potential failure and the

signs are usually apparent in the form of cracks, fracture lines, deformation, dents and other visual indicators of abnormality. These safety checks for frame stress are important to prevent accidents, injury to the cyclist and product failure of a Yeti frameset.

## DISCLAIMER

Yeti Cycles is not responsible for any damages to you or others arising from riding, transporting or other use of your bicycle. In the event that your frame breaks or malfunctions, Yeti Cycles shall have no liability or obligation beyond the repair or replacement of your frame pursuant to the terms outline in this warranty.

## CONTACT INFO

Yeti Cycles  
600 Corporate Circle, Unit D  
Golden, CO 80401  
(p) 303-278-6909  
(f) 303-278-6906  
[WWW.YETICYCLES.COM](http://WWW.YETICYCLES.COM)

## BUSINESS HOURS

Monday-Friday  
8AM-11:30AM, 1:00PM-5:30PM  
(Mountain Time)