



# YETI 160E EP8 OWNER'S MANUAL

# TABLE OF CONTENTS

BRAND OVERVIEW	03	WARRANTY	29
FRAME FEATURES	04	APPENDIX A. ASTM DESIGNATION	30
GEOMETRY	05	APPENDIX B. EU DECLARATION	31
FRAME STANDARDS	06	APPENDIX C. UK DECLARATION	32
SETUP	07		
MAINTENANCE	09		
FRAME ASSEMBLY	10		
E-COMPONENT ASSEMBLY	13		
FOX TRANSFER POST INSERTION GUIDE	17		
HANDLEBAR WIRING	18		
EXPLODED VIEW	19		
ASSEMBLY BILL OF MATERIAL	20		
REBUILD KITS	22		
ADDITIONAL INFORMATION	25		
FAQ	26		

# CONGRATULATIONS ON YOUR PURCHASE OF A NEW YETI.

We are confident your new bicycle will exceed your expectations for value, performance, and ride quality. Each frameset and component has been custom specified and designed to enhance your riding experience. Whether you are a beginner cyclist, or a seasoned pro, your Yeti bicycle will provide endless hours of two-wheeled fun.

This model specific manual is designed to be used in conjunction with the general Yeti Owner's Manual and the manuals supplied by the suspension manufacturers. If you did not receive the Yeti owner's manual or the manual provided by the suspension manufacturer, download the materials off the Internet, or contact your local dealer. Bicycling can be a hazardous activity even under the best of circumstances. Proper maintenance of your bicycle is your responsibility and when done properly helps reduce the risk of injury and damage to your bicycle. **The 160E is made specifically for off-road use only.**

**WARNING:** Make sure you review and understand the warnings, instructions, and content of this manual and accompanying manuals for your bicycle.

**WARNING:** Technological advances have made bicycles and bicycle components more complex and the pace of innovation is increasing. It is impossible for this manual or the accompanying manuals to provide all the information required to properly repair and/or maintain your bicycle. In order to help minimize the chances of an injury, it is critical for you to have work performed by an authorized Yeti retailer.

**WARNING:** Mounting biking is an inherently dangerous activity. The user frequently performs "Unsafe Maneuvers," so be aware, and make sure you have the requisite skills to operate a mountain bike. This risk is assumed by the user.

This manual outlines basic setup and maintenance recommendations of your new Yeti. Because it is impossible to anticipate every situation or condition that may occur during the assembly, setup, and maintenance of your bicycle, Yeti recommends that all service and repairs be performed by your local authorized Yeti Dealer.

This manual contains many "Warnings" and "Cautions" concerning the consequences of failure to maintain or inspect your bicycle. The word "Warning" indicates a potentially hazardous situation in which, if not avoided, could result in serious injury or death. The word "Caution" indicates a potentially hazardous situation in which, if not avoided may result in minor injuries or damage to your bicycle or a component of your bicycle. Be sure to read and understand all of the Warnings and Cautions listed in the manual.

# THE LOWDOWN ON THE 160E AND ITS FEATURES.

## FRAME FEATURES

### 1 SIXFINITY PATENT PENDING SUSPENSION SYSTEM

The 160E delivers 160MM of travel with our patent pending Sixfinity Technology. Efficient pedaling performance pairs with a supportive yet active feel when the going gets rough.

### 2 HIGH MODULUS CARBON FIBER MAIN FRAME AND SWING ARM

High modulus carbon provides a stiff, strong and light weight chassis.

### 3 FLOATING COLLET AXLE SYSTEM ON PIVOTS EXTENDS BEARING LIFE

Floating colleted pivot axles help create a stiff interface between the front and rear triangles of the frame. Enduro Max sealed bearings keep things moving freely at the pivots.

### 4 POWERFUL EP8 DRIVE UNIT AND RANGE EXTENDING 630WH BATTERY

Driven by Shimano's EP8 drive unit you have 85 Nm of torque at your disposal. Paired with a 630Wh battery, you can focus less on battery life and more on shredding miles of trail.

### 5 LEVERAGE RATE FLIP CHIP

Unique to Yeti's Sixfinity suspension platform has the ability to change the leverage rate. Flip the rate chip to suit your riding style, the trail of the day.

### 6 INTEGRATED HEAD TUBE (41MM/52MM)

Using an integrated head tube design on the 160E allows for a larger head tube with more area, which results in increased stiffness, and lower overall ride height without compromising any performance.

### 7 CUSTOM REINFORCED FRAME COVERS AND RIBBED CHAIN GUARDS TO DECREASE CHAIN SLAP NOISE

Custom reinforced frame covers keep the frame protected from any direct impacts and prevents dirt and debris from damaging critical frame components. Reducing the annoying sounds caused by chain slap, the 160E ribbed rubber chainstay and seatstay guards keep things quiet while riding and protect the frame.

### 8 INTERNALLY MOLDED CARBON TUBES AND CABLE TRAYS FOR HASSLE-FREE CABLE ROUTING AND A QUIET BIKE

The 160E is designed with rattle-free cable ports, down tube cable trays and internally molded routing tubes in the chainstay keeping the bike quiet and clean looking while reducing cable rub and overall maintenance.

### 9 INTEGRATED AXLE AND UNIVERSAL DERAILLEUR HANGER SYSTEM

Dedicated 12 x 148 Boost dropouts with SRAM's universal derailleur hanger provide strength, stiffness and easy hanger and wheel installation.

### 10 UNINTERRUPTED SEAT TUBE FOR COMPATIBILITY WITH LONGER TRAVEL DROPPER POSTS

Getting the saddle out of the way allows you to tear down the steepest descents without worrying if your saddle is going to buck you. The 160E's uninterrupted seat tube design lets you fit the longest dropper possible for your saddle height.

# GEOMETRY

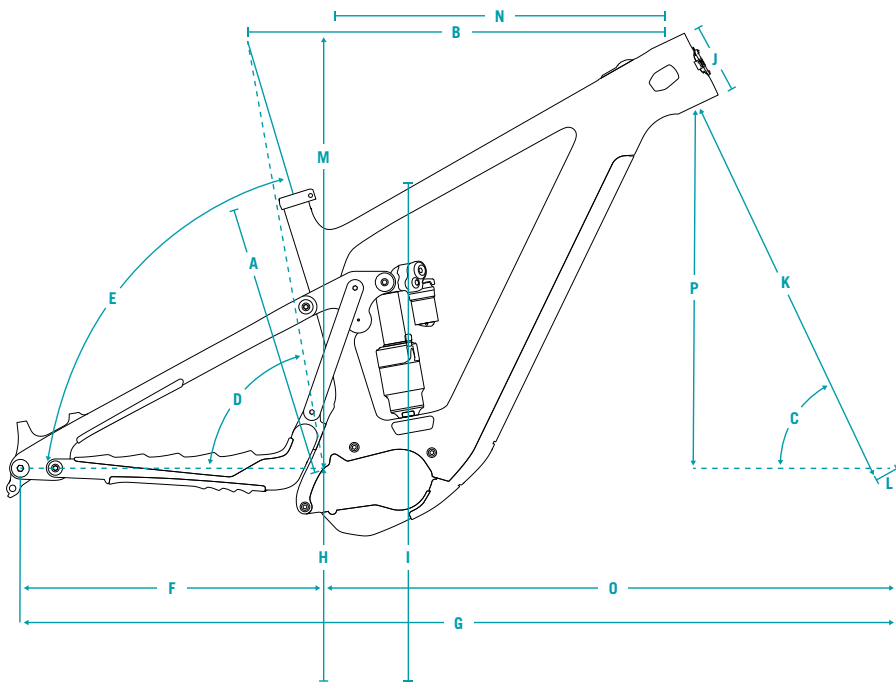

	170MM FORK	SM	MD	LG	XL
<b>A</b>	<b>SEAT TUBE LENGTH</b>	325	356	396	441
<b>B</b>	<b>EFF. TOP TUBE LENGTH</b>	561	592	614	642
<b>C</b>	<b>HEAD TUBE ANGLE°</b>	64.5	64.5	64.5	64.5
<b>D</b>	<b>EFF. SEAT TUBE ANGLE°</b>	78	78	78	78
<b>E</b>	<b>ACTUAL SEAT TUBE ANGLE</b>	72	72	72	72
<b>F</b>	<b>CHAINSTAY LENGTH</b>	446	446	446	446
<b>G</b>	<b>WHEELBASE</b>	1210	1241	1264	1294
<b>H</b>	<b>ESTIMATED BB HEIGHT</b>	351	351	351	351
<b>I</b>	<b>STANDOVER</b>	756	756	756	756
<b>J</b>	<b>HEADTUBE LENGTH</b>	95	98	104	115
<b>K</b>	<b>FORK (AXLE TO CROWN)</b>	588	588	588	588
<b>L</b>	<b>FORK (OFFSET)</b>	44	44	44	44
<b>M</b>	<b>STACK</b>	618	621	626	636
<b>N</b>	<b>REACH</b>	428	458	478	503
<b>O</b>	<b>FRONT CENTER</b>	764	795	818	848
<b>P</b>	<b>VERTICAL FORK TRAVEL</b>	153	153	153	153

## FIT

<b>SMALL</b>	5'1" (155 CM) – 5'7" (170 CM)
<b>MEDIUM</b>	5'5" (165 CM) – 5'11" (180 CM)
<b>LARGE</b>	5'10" (178 CM) – 6'3" (191 CM)
<b>X-LARGE</b>	6'1" (185 CM) – 6'7" (200 CM)

# FRAME STANDARDS

<b>TRAVEL</b>	160MM
<b>WHEEL SIZE</b>	29"
<b>FRAME SIZE</b>	SM, MD, LG, XL
<b>REAR SHOCK</b>	205MM X 65MM
<b>BOTTOM BRACKET</b>	SHIMANO EP8
<b>REAR WHEEL</b>	148MM X 12MM (BOOST)
<b>SEATPOST</b>	31.6MM
<b>CHAINLINE</b>	53MM AND 55MM
<b>HEADSET</b>	INTEGRATED 41MM/52MM TAPERED
<b>REAR BRAKE POST MOUNT</b>	180MM
<b>SHOCK HARDWARE</b>	TOP: TRUNNION MOUNT, BOTTOM: M8X43.69MM
<b>MIN/MAX CHAINRING</b>	34T MIN/34T MAX
<b>MIN MAX REAR ROTOR</b>	180MM MIN/220MM MAX
<b>AXLE SPEC</b>	172MM M12X1

# SETUP

**INITIAL SETUP SHOULD BE PERFORMED BY A CERTIFIED MECHANIC PRIOR TO MAKING ADJUSTMENTS OR FIRST USE.**

## SADDLE HEIGHT

- Loosen headtube port that the dropper housing runs through and ensure dropper housing moves freely, unless using wireless dropper post.
- Loosen the seat collar and adjust to your desired height.

**WARNING:** DO NOT EXCEED THE MINIMUM INSERTION DEPTH MARKED ON THE SEATPOST

- Once you have adjusted the seatpost to your desired height, re-tighten the seat post collar and headtube port bolt to their recommended torque specification.

## SUSPENSION / TIRE SETUP

- Visit <https://shocksetup.yeticycles.com/bikes> for complete instructions on setting up your front and rear suspension and recommended tire pressures.

**WARNING:** Only make suspension adjustments while completely stopped and not moving.

- Check tire pressure before every ride.

**WARNING:** Do not exceed max tire pressure that is labeled on the sidewall of the tire. Too low of tire pressure could lead to pressure loss known as burping and increase the chance of tire and rim damage.

- The 160E has a flip chip that adjusts the bikes leverage rate. The frame comes stock in 30%.
- To adjust the leverage rate up or down by 5%, support the rear wheel and remove the lower shock bolt.
- Take out the stock 30% rate chips and replace with the additional chip set that came with your frame.
- Position the chips in the direction you would like to move the leverage rate and reinstall the lower shock bolt with the addition of a small amount of blue Loctite 242 on the bolt threads.
- If more setup information is required, please talk to a certified Yeti dealer or reference the suspension manufacturers manuals that came with the bike or visit their website.

## COCKPIT SETUP

- Loosen the stem bolts to adjust handlebar. Do not loosen the bolts that secure the stem to the steerer tube to make this adjustment.
- Roll the bars and re-torque to manufacturers recommended settings.
- Loosen the bolts securing the brake and shift controls and move them so that they are safely accessible while operating the bike.
- The brake and shift controls can be adjusted by moving them side to side or rolled up and down to achieve desired location. Torque controls to the manufacturers recommended torque specification once desired position is achieved.

## CHARGING

- The battery ships partially charged so the system must be fully charged prior to first use.
- Pull the charging cover up and away from the charging port. It will stay connected to the charging port.
- Before installing charging plug, ensure proper alignment of charger plug.
- If installed properly the light on the charger will illuminate indicating the battery is being charged.
- Charging time will vary based on starting charge level. With the supplied EC-60002 charger it will take 10.2 hours to reach full charge from a fully drained battery.
- After battery is fully charged remove charger plug from charging port and replace port cover.
- Please note, an adaptor is needed for off bike charging of the battery. BT-E8035
  - Align adaptor and install on battery.
  - Plug charger into battery adapter per the above steps.

**WARNING:** Do not attempt to charge the bike while riding the bike.

- See STEPS manual for further operation and safety information.

# SETUP CONTINUED

**INITIAL SETUP SHOULD BE PERFORMED BY A CERTIFIED MECHANIC PRIOR TO MAKING ADJUSTMENTS OR FIRST USE.**

## TURNING ON/OFF THE SYSTEM

- Push down power button on the toptube and hold briefly to turn on or off the system.
- The battery must be charged for system to turn on.
- Power cannot be turned on while the battery is charging.
- If the bike has not moved for 10 minutes, the power will shut off automatically.
- Ensure the bike is stationary prior to powering on the system.

## MODE SELECTION

- The support mode can be selected using the mode switch on the left side of the handlebars once the power has been turned on.
- Toggle between the 4 modes, Off, Eco, Trail and Boost, by pushing the up or down buttons on the mode switch. The direction of mode selection can be customized in the Shimano E-Tube app.
- To activate Walk mode, push and hold the button that decreases the support until walk mode appears on the display. The bike must be stationary in order to enter walk mode. Release and push and hold again to start the walk assist.
- Walk support will only be active when the button is pushed and held.
- Further mode switch operation information can be found in the Shimano mode switch user manual included with you bike or inline at <https://www.shimano-steps.com/>

## DISPLAY OPERATION

- See Shimano STEPS user manual provided with your bike or at the Shimano STEPS website, <https://www.shimano-steps.com/>, for operation instructions.

## E-TUBE PROJECT

- System updates and system customization is all available through the Shimano E-Tube app.
- Download the E-Tune app on your phone and enable Bluetooth to connect to your bike.
- Follow the E-Tube app instructions on the Steps website for connection, updates and customization guidance.
- For more information go to the Shimano E-Tube website, <https://bike.shimano.com/>

## BATTERY REMOVAL AND INSTALLATION

- To remove the battery, insert a M4 allen wrench into the small hole at the top of the battery guard.

**WARNING:** Do not remove the collet bolt or axle that is on the non drive side of the down tube near the head tube.

- Ensure the wrench is secure in the latch bolt head and turn clockwise ¼ turn until the battery releases and falls onto the secondary catch.
- Supporting the battery with your hands, insert your finger between the frame and the battery cover and depress the catch to release the battery fully.
- Lower the top of the battery down and then pull the battery out from the lower mount.
- To reinstall the battery, insert the bottom of the battery into the lower mount in the frame.
- Ensure the lower mount is properly seated then press the upper part of the battery into the top mount until you hear 2 clicks.
- Double check that the battery is fully secured, and it is not resting on the secondary catch.



# KEEP YOUR YETI FRESH AND CLEAN

## MAINTENANCE OVERVIEW

Following these guidelines will help maintain the performance of your bicycle and prevent more serious problems from arising. It is important to remember that service intervals can vary depending on climate, trail conditions and riding frequency. Servicing your bike requires special knowledge and tools. If you are unsure about working on your own bicycle, contact your authorized Yeti Dealer for more information on general bicycle maintenance.

This owner’s manual should be used in addition to the manuals supplied with you bike by the component manufacturers. If those manuals are missing, most component manuals can be found on the component manufacturers website or contact your local dealer.

Any component of the SHIMANO STEPS system should only be serviced by a certified mechanic. All STEPS related service should be taken to a Yeti authorized dealer and not attempted by the user.

Before any maintenance is performed be sure to turn off the E drive system and remove battery.

SCHEDULE	BEFORE EACH RIDE	MONTHLY	3 MONTHS	ANNUALLY
Clean and lube chain	•			
Check tire pressure	•			
Clean bike of mud and debris	•			
Check brake function	•			
Ensure all cable ends are covered with crimped cable end caps	•			
Check rims for deformations or cracks	•			
Check shock pressure		•		
Check for loose bolts and tighten, if necessary		•		
Check headset and tighten/loosen, if necessary		•		
Check for firmware updates using e-tube app		•		
Thoroughly clean pivot points with a rag (do not lubricate)		•		
Check / replace brake pads			•	
Check tires for wear			•	
Check spoke tension, retention, if necessary			•	
Check chain for wear, replace if necessary			•	
Complete tune-up performed by an authorized Yeti Dealer				•

## TORQUE

Yeti strongly recommends using a torque wrench when assembling your frame. Torque specifications for individual parts on the 160E are listed below, as well as in the step by step assembly instructions later in the manual. For general bicycle maintenance please consult the torque specifications of the component you are adjusting.

### KEY TORQUE SPECS

ITEM #	DESCRIPTION	TORQUE (NM)
4.8	Main pivot axle	20
4.14	Clevis pivot bolt, M12	12
4.42	Collet axle, 10mm long head	12
4.9	Collet wedge bolt, large	14
4.12	Link, pivot hardware, male, 15MM	15
4.36	Universal derailleur hanger	25
4.21	Motor mount screw, M8 BHCS	12
4.44	Collet wedge bolt, small	8
4.11	Shock bolt, M10	12
4.59	Tie link bolt, long	12
4.10	Tie link bolt, short	12
4.39	Yeti seat clamp, bolt on, 31.6	5

# FRAME ASSEMBLY

## YETI TIPS

Make sure your tools are in good condition. A worn allen key can round the hex on a bolt not allowing for proper torque. Torque settings are listed throughout the instructions. It is important to prep all bolt threads. The instructions denote whether to use a Loctite compound or grease.

**WARNING:** Service on Yeti bicycles requires special knowledge and tools. Yeti Cycles recommends that all service and repairs be performed by an authorized Yeti Dealer-

**WARNING:** All frame components must be installed for proper function of this bike. Removal of any frame component could result in frame damage and injury.

## TOOLS NEEDED

- 1.5mm allen key
- 2mm allen key
- 2.5mm allen key
- T10 Torx
- 3mm allen key
- 4mm allen key
- 5mm allen key
- 6mm allen key
- 10mm allen key
- Guide pin tool (Or two)
- Torque wrench
- Grease
- Blue (243) Loctite

## PREP HARDWARE PER THE ASSOCIATED ASSEMBLY DRAWING

- 1x SHCS M5 x 14L (4.3.6): Blue Loctite 243
- 2x 15mm Collet Axle (4.8): Grease shaft and head
- Small (4.45) and Large (4.9) Collet Wedge Bolts: Grease wedge and threads
- 2x Short (4.10) and 2x Long (4.61) Tie Link Pivot Bolts: Blue Loctite 243
- 2x Upper Shock Bolts (4.11): Blue Loctite 243
- 1x Rocker Link Pivot Bolt, Male (4.12): Blue Loctite 243
- 1x Rocker Link Pivot Axle (4.13): Grease shaft
- 4x M12 Clevis Bolts (4.14): Blue Loctite 243
- 4x Main Pivot Race Extenders (4.15): Grease inner surface
- 4x each 12/15mm Race Reducers, Small (4.16) and Large (4.17)
- 2x 12/10mm Race Reducer (4.18): Grease reducer OD
- 6x Motor Mount Bolts (4.21): Blue Loctite 243
- 2x M5 H20 Bolts (4.34): Grease
- 2x M5 x 12L FHCS (4.39): Blue Loctite 243
- 1x M10 Collet Axle, Long Head (4.43): Grease shaft and head, Blue Loctite 243 on threads
- 1x M8 Lower Shock Bolt (4.46): Blue Loctite 243
- 1x CS Guard Retension Screw (4.64): Blue Loctite 243



### 01

Apply grease to the bearing bores of the rear SS Pivot. Press 2x 3802 Bearing (4.31) using provided tools. Make sure bearings are fully pressed into rear triangle.



### 02

If not already completed, install non-drive side Rocker Pinch Bolt (4.3.6) into non-drive side Rocker Link but leave loose. Press/Slide 1x 15/17mm Bearing Reducer (4.3.5) into the inside of each lower bearing on drive-side and non-drive side Rocker Links. Make sure reducer is fully seated in bearing.



### 03

Assemble the non-drive side Rocker Link (4.3), Rocker Bridge (4.60), and drive-side Rocker Link (4.2) together using 2X M5 FHCS (4.39). To help align the Rocker links and Bridge, you may also temporarily install the upper Timing Link bolts (4.61)



### 04

Install Rocker Link Assembly to the Front Triangle and secure with Link Pivot Axle (4.13) and male Link Pivot Bolt (4.12). Make sure pinch bolt on non-drive side Rocker Link allows bearing to float and secure flush onto frame.

**Torque Link Pivot hardware to 15 Nm.**

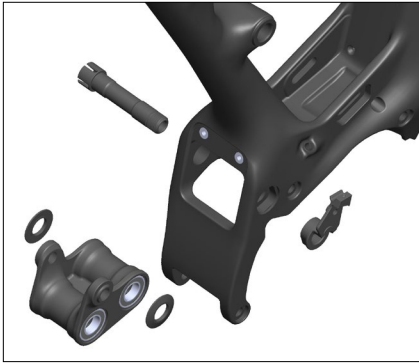

**05**

Lightly grease the bore and collet nut interface on the Front Triangle main pivot interface. Install Lower Switch Link Assembly (4.1) with two Race Extenders (4.15) into the Front Triangle and secure with 15mm Collet Axle (4.8) and Chain guide Mount Collet Nut (4.47).

**Torque to 20-25 Nm**

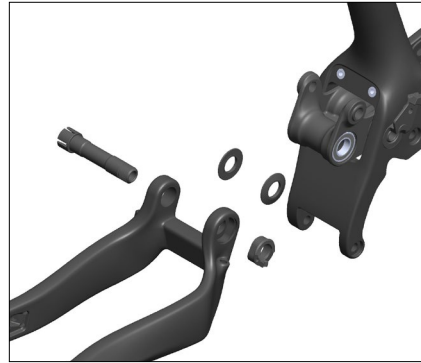

**06**

Lightly grease bore and collet nut interface of chainstay main pivot interface. Install remaining 15mm Race Extenders (4.15) onto Lower Link (4.1) and place chainstay onto Link. Secure with 15mm Collet Axle (4.8) and Cable Clamp Collet Nut (4.58).

**Torque to 20-25 Nm**

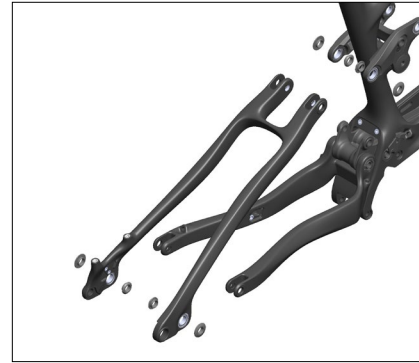

**07**

Install 2x Bearing Reducer, Large Flange (4.17) and 2x Bearing Reducer, Small Flange (4.16) to the outsides and insides of the Rocker Link Assembly rear bearings.

Repeat for seatstay Clevis interface.

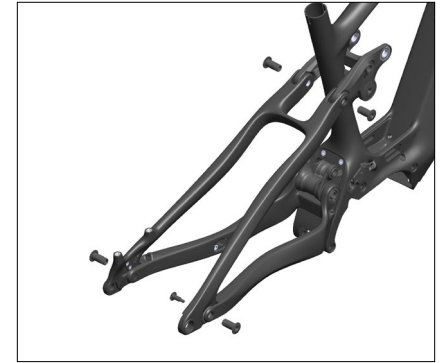

**08**

Install seatstay onto frame, aligning first at the Rocker Link Assembly. Use 12mm guide pin to align and secure with 2X Clevis Bolt (4.14). Align the chainstay and seatstay clevis interface using 12mm Guide Pin and secure with 2X Clevis Bolt (4.14).

**Torque all clevis bolts to 12 Nm**



**09**

Install Cable Port Cover, Single (4.27) to the inside of the chainstay non-drive side surface and secure lightly with M4 FHCS (4.20).

Repeat installation of port cover on Front Triangle non-drive side.

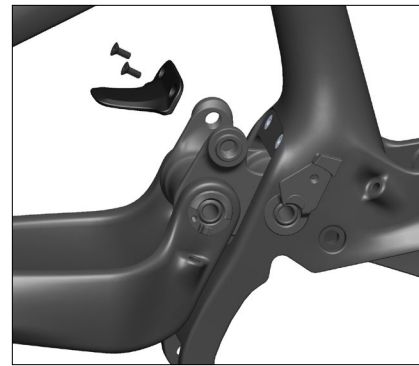

**10**

Install Switch Link Fender (4.38) to the Front Triangle using 2X FHCS (4.20) Torque to 2.5 Nm or until snug.



**11**

Tighten non-drive side Rocker Link pinch bolt and torque to 5-6 Nm Torque the 2X M4 FHCS securing the Rocker Links and Bridge to 5 Nm.

Note: This bolt must be loosened prior to link removal.



**12**

Install Timing Link (4.4) and Timing Link (4.5) onto the Rocker Link Assembly using 2X Tie Link Bolt, Long (4.61) and to the Switch Link Assembly (4.1) using 2X Tie Link Bolt, Short (4.10).

**Torque all Tie Link bolts to 12 Nm.**



**13**

Install 2X Collet Wedge Bolt, 15mm (4.9) into the two 15mm Collet Axles at the main pivot.

**Torque to 14-15Nm.**

**QC CHECK:** Cycle Rear Triangle through to make sure motion is smooth.



**14**

Install 2X 12/10mm Reducer (4.18) on the insides of the front Rocker Link bearings. Install Shock into frame using 2X Upper Shock Bolt (4.11). Secure lower eyelet with 30% Shock Chips (4.29 & 4.30), 8mm x 63L Shoulder Screw (4.46) and Washer (4.28).

**Torque fasteners to 12 Nm**

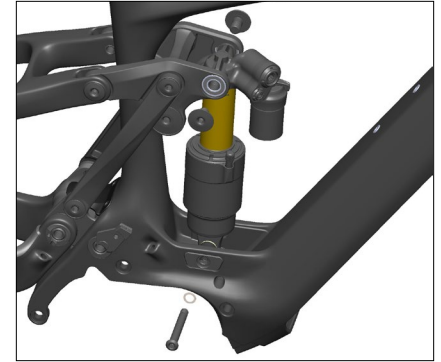

**15**

Install UDH Derailleur Hanger (4.37) into seatstay.

**Torque (left-hand thread) to 25 Nm.**



**16**

Install chainstay Guard Retention Screw (4.64) through chainstay Guard and into the opposing clevis bolt.

**Tighten until snug - be careful to not overtighten!**

Note: This bolt must be loosened prior to removing the Clevis Bolt (4.14) it threads into.

# E-COMPONENT ASSEMBLY

FIRST OPERATIONS MAY BE PERFORMED IN A STAND OR FLIPPED UPSIDE DOWN, DEPENDING ON BUILDER PERSONAL PREFERENCE.

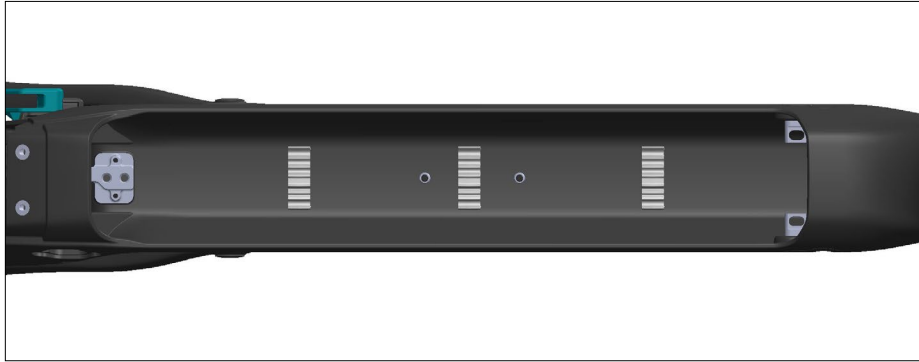

01

If installing a wired drivetrain, route a length of shifter housing from the non-drive side headtube port (lower hole), down the downtube being secured in the second-from-left opening in the cable trays.

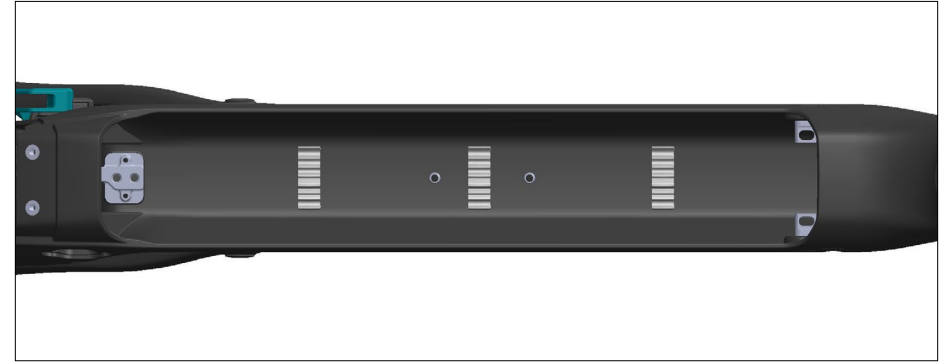

02

Route shifter housing past the lower battery mount pad and into the motor cavity. Exit the housing from the front triangle port and loop over the top of the Collet Nut clamp features and into the drive-side chainstay.

03

Route rear brake housing forward, ensuring a generous strain relief from caliper to cable port entry to account for motion between chainstay and seatstay. Secure to chainstay with a Single Port Cover (4.27) and M4 FHCS (4.20)

04

Route brake housing into Front Triangle ensuring adequate strain relief between front and rear triangle. Route brake housing up either the left-most or right-most channel in cable trays and exit the non-drive side port hole on the headtube.



05

Install Speed Sensor (4.6.7) to the Seatstay with supplied Shimano M3 fasteners.

**Tighten to 0.6Nm (hand tight).**

Route E-wire through the chainstay ensuring adequate strain relief. Exit the chainstay and loop sensor wire with brake housing into the Front Triangle.



06

Install 2X Grommet (4.32) around sensor wire at each chainstay port and push into frame until flush.

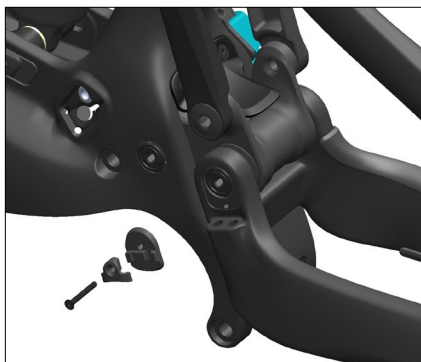

09

Install Base, Housing Clamp (4.53) underneath brake housing and sensor wire and secure with Clamp, Housing Clamp (4.54) and M3 FHCS (4.33).

**Tighten hand-tight.**



10

Clamp shifter housing and sensor wire to the rear Main Pivot Collet Nut (4.57) and secure with Housing Clamp (4.56) and M3 SHCS (4.55).

**Tighten hand-tight.**

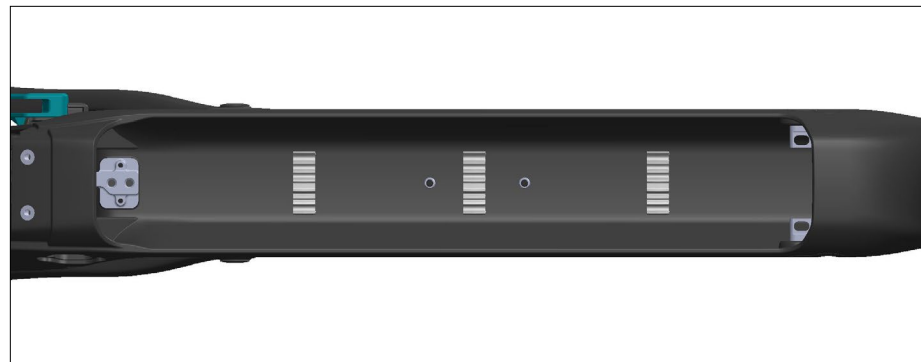

11

If assembling a non-wireless seatpost kit, route length of dropper/shifter housing starting at the drive-side Lower Cable Port. Clip housing into Management Trays in the first or second-position from drive-side. Pass the housing on either side of the battery mount insert, into the motor cavity, and up the seattube. Ensure adequate length from head tube and out of seat tube to ensure setup compatibility.

12

Route a 1200 mm Shimano E-wire down the downtube. Insert into drive-side Upper cable port and route down downtube securing in one of the small E-wire channels. Route wire through non-drive side pass-through past battery mount. Leave approx. 6-8" of wire exposed from headtube port exit.



13

Route a 1200 mm Shimano E-wire down the downtube. Insert into drive-side upper cable port and route down downtube securing in one of the small E-wire channels. Route wire through non-drive sides pass-through past battery mount. Leave approx. 6-8" of wire exposed from headtube port exit.

14

Install the Satellite Power Switch (4.6.6) into the top of the Top Tube. Tuck front lip of switch in before placing flush. Secure with provided Shimano screw (4.6.5). Tighten hand-tight (Shimano spec: 0.6 Nm) Route switch wire down downtube securing in the remaining E-wire channel. Route through non-drive side pass-through past the battery mount.

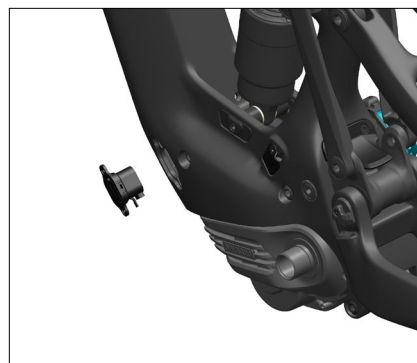

15

Route the Satellite Charge Port harness (square plug) out the hole in the frame non-drive side and attach the Satellite Charge Port (4.6.3) outside of the frame.

16

Attach the main power cable harness (circular plug) into the motor. Pay attention to the keying by aligning the arrow on the harness clip to the motor receptacle.

**ALL BATTERY MOUNT ADJUSTMENTS SHOULD BE PERFORMED BY AUTHORIZED YETI CYCLES DEALER. DO NOT ATTEMPT TO ADJUST ANY OF THE HARDWARE RELATED BATTERY MOUNT.**

## 17

Plug the E-wires into the motor on the non-drive side receptacle using Shimano E-wire tool. Computer and Remote Switch wires can be plugged into either circular port. Speed Sensor wire end is keyed and will only fit into one corresponding keyed port on the motor. Use caution to make sure the correct port is being used.

## 18

Using 2-4 small zip ties, bundle the group of E-wires cleanly together, adding loops as necessary. Keep bundle as close to frame and motor as possible to minimize free length.

Make sure that brake, shifter (if applicable), and dropper (if applicable) housing is routed cleanly from downtube into motor cavity and can be pushed relatively easily up against the frame wall.

## 19

Tuck E-wire bundle inside motor cavity using the open space on the non-drive side. Carefully lower motor into frame. E-wire bundle and main power harness should group and route along the non-drive side up to in front of the motor and into the downtube.

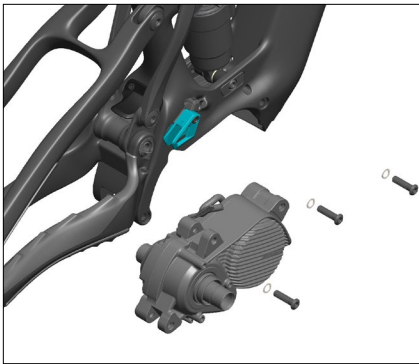

## 20

Using care to not pinch E-wires or crimp any housing, gently press motor into cavity until fasteners can be loosely installed. Install 6x Motor Mount Shoulder Screw (4.21) with Washer (4.28) through frame and into Motor.

**TIGHTEN DRIVE-SIDE SCREWS FIRST.**

**Torque to 12 Nm**

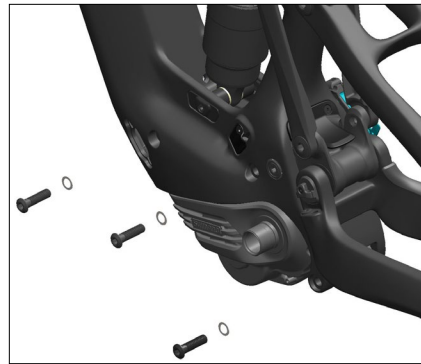

## 21

After drive-side screws have been torqued, tighten non-drive side screws. The motor bushings should extract and fill space against the frame.

**Torque remaining screws to 12 Nm.**

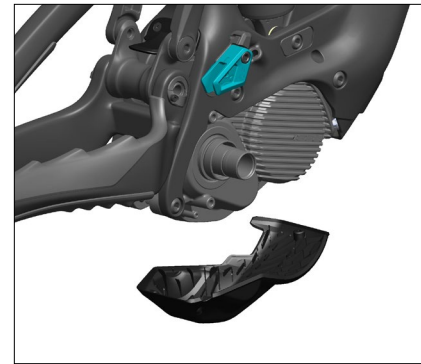

## 22

Attach the Motor Guard (4.67) to the Motor using 2X supplied Shimano Phillips screws (hand-tight). Install screws into the two side holes in the guard.

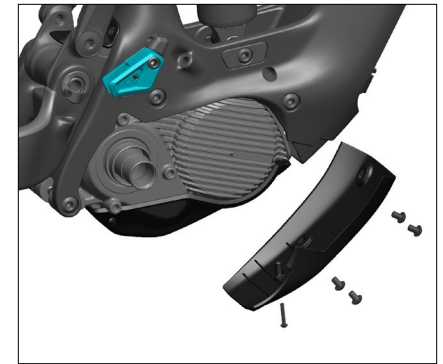

## 23

Attach the Lower Edge Guard (4.66 - appropriate size for bike) over the Lower Edge Guard.

Secure using 4x M5 BHCS (4.62) and 1x M3 BHCS (4.65) through the Motor Guard and into the Motor.

Tighten M3 screw until snug (hand-tight), and M5 BHCS to approximately 2 Nm or until hand-tight.



25

Install Battery (4.6.2) into the downtube. Battery should clip in firmly and latch without pinching any wires or housing. Install Battery Guard (4.7) onto the Battery using 4x M4 BHCS (4.63). Snug the 4x BHCS until hand-tight.



26

Install Battery Guard (4.7) onto the Battery using 4x M4 BHCS (4.63). Snug the 4x BHCS until hand-tight.



27

Install OnesUp O-Ring onto the Chainguide Mount Shoulder Bolt (4.50). Secure OneUp Components Chainguide (outer and inner, 4.51 and 4.52) with Shoulder Bolt (4.50) onto the Chainguide Mount Collet Nut (4.47).

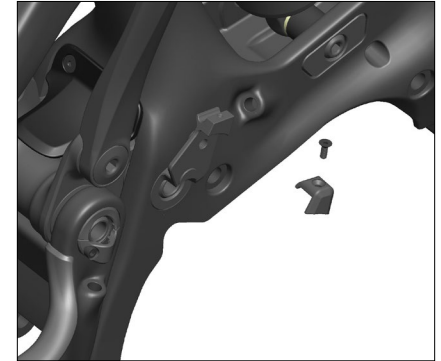

28

Install Housing Clamp, Chainguide Mount (4.48) around shifter housing (if applicable) and onto the Chainguide Mount Collet Nut (4.47) using 1x M3 FHCS (4.49). Tighten until snug. If overtightened, shifting performance can be effected.

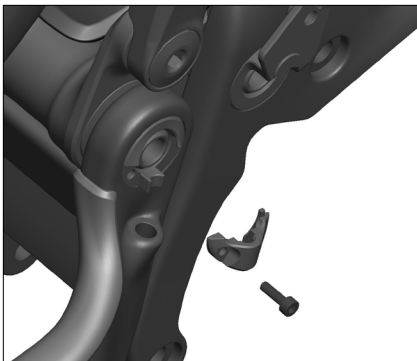

29

Install Cable Clamp, chainstay Collet Nut (4.57) onto the Collet Nut, Housing Clamp (4.58) by inserting the small tab under the collet nut overhang. Secure with M3 x 10L Cap Screw (4.56). Tighten screw until snug around housing, or hand-tight if assembling a wireless drivetrain kit. If overtightened, shifting performance can be effected.



30

Install Base, Housing Clamp, chainstay Collet Head (4.54) and Clamp, Housing Clamp, chainstay Collet Head (4.55) into the non-drive side collet head in the chainstay with a M3 x 25L FHCS (4.33). Ensure that brake line and speed sensor wire have adequate strain relief to the front triangle and not being pulled, tugged, or bent throughout travel. Tighten clamp around Speed Sensor wire and brake housing until snug (hand-tight).



31

Install a Shift + E Cable Port Cover (4.24) or E-Only Cable Port Cover (4.25) (kit-dependent) with a Cable Port Cove Base (4.22) onto the drive-side headtube and secure with M4 FHCS (4.19). Tighten until snug. Install a Shift + Brake Cable Port Cover (4.23) or Brake-Only Cable Port Cover (4.26) (kit-dependent) with a Cable Port Cover Base (4.22) onto the non-drive side headtube and secure with M4 FHCS (4.19). Tighten until snug.

32

Install Shimano Chainring onto Motor and secure with chainring Lockring. Note that Lockring is LEFT HAND thread. Torque to 35-45 Nm using crow's foot attachment. Ensure chainring sits in between chainguide halves.

33

Install Shimano cranks per manufacturer instructions. Install crankarm cap and tighten to 0.7 - 1.5 Nm. Torque 2X Crank Arm pinch bolts to 12-14 Nm



# DROPPER POST INSERTION GUIDE

Droppers are an essential tool for the modern mountain bike but proper clearance checks are required before heading out for your first ride.

The key checks are as follows:

Ensure your dropper is short enough to fit into the seat tube without interfering with the frames structure but you are still able to achieve your desired BB-Saddle measurement. See the max insertion depth chart to confirm this distance for wired and wireless posts.

There are some scenarios where you can fit a longer dropper in your frame but when you drop your dropper the saddle or battery for AXS posts could interfere with your tire during a suspension compression. See the Min BB-Saddle at full drop to confirm this distance.

Always perform a final check to ensure your post is installed to at least the minimum insertion line. Also, compress the dropper and suspension, let the air out of your shock, to ensure there is no tire interference to the saddle or AXS battery at full bottom out.

We strive to spec out dropper lengths to provide the maximum drop for the highest percentage of our riders. There is a wide range of saddle heights for every frame size. There is a possibility saddle height could fall outside of this range. A small percentage of customers might find they require a shorter or longer post given their saddle height.

Please ensure you check the minimum dimensions in the below tables before going for your first ride. Failure to do so could result in tire to saddle rub or tire to battery contact for AXS posts.

Please confirm both of these measurements, they are both required to ensure proper dropper fitment.

If you have any questions, please contact Yeti or your local bike shop.

MINIMUM BB TO SADDLE CABLED DROPPER (MM)*		
FRAME SIZE	X-SMALL	498.5**
	SMALL	497.4**
	MEDIUM	496.5**
	LARGE	No min
	X-LARGE	No min
	XX-LARGE	No min

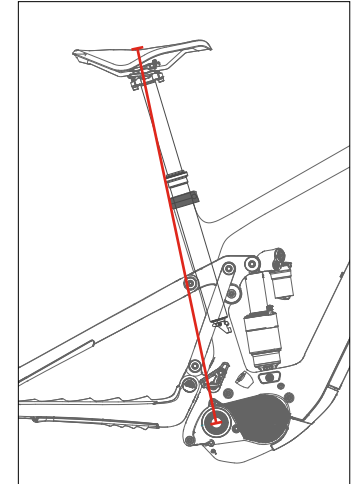

\*These measurements are only for cabled droppers. Please make sure if you have a wireless post you confirm that there is not any interference of the tire hitting the battery when the post is fully dropped and the suspension is fully compressed.

\*\*If you go lower then listed minimum you run the risk of tire to saddle interference.

MAX INSERTION WIRELESS DROPPER (MM)*		
FRAME SIZE	X-SMALL	232.2
	SMALL	242.8
	MEDIUM	277.4
	LARGE	316.8
	X-LARGE	331.0
	XX-LARGE	331.0

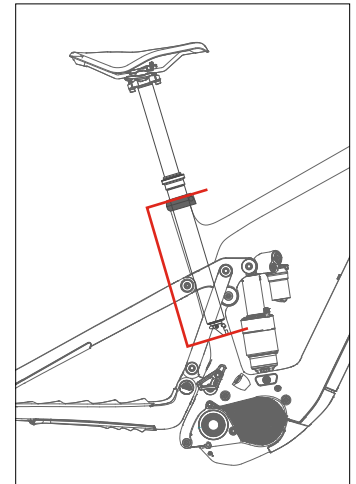

\*Subtract 34mm for a cabled dropper to accommodate housing bend angle.

# HANDLEBAR WIRING

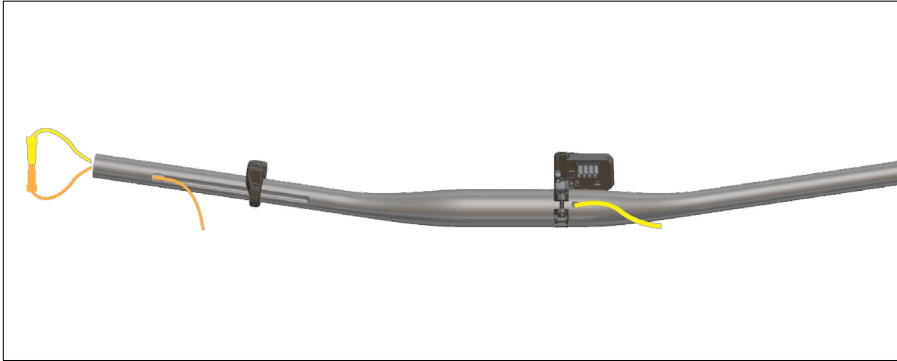

## 01

- Insert the mode switch wire (Orange) in the hole in the left side of the handlebar and push until it exits the left side of the bar end.
- Using an internal cable routing tool (Yellow), insert the tool into the hole near the center of the handlebar and push through until it exits the left side bar end.
- Connect the mode switch wire (Orange) to the internal cable routing tool (Yellow) and pull the internal cable routing tool back through the hole at the center of the handlebar.

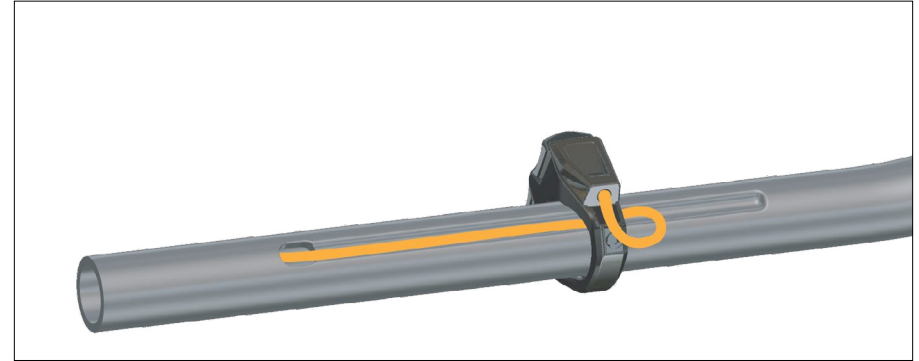

## 02

- Install the mode switch in the correct location next to the grip on the rider's left side of the handlebar. Take care to ensure the mode switch wire is aligned in the groove under the bar and passes under the clamp before connecting to the mode switch. Use a 3mm hex wrench to tighten the mode switch clamp bolt to 1.5Nm (13.8 in-lb). Ensure that the mode switch wire is seated in the groove when installing the grip to avoid damaging the wire.

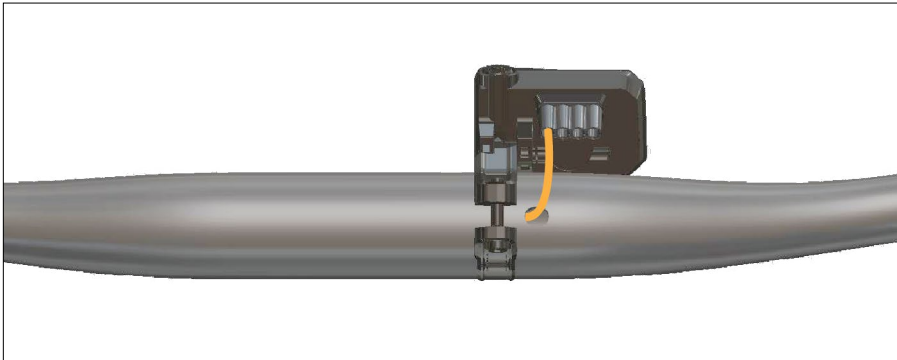

## 03

- Install the Shimano cycle computer onto the handlebar, directly to the right of the stem. Use a 3mm hex wrench to tighten the clamp bolt to 0.8Nm (7.1 in-lb).
- The wire from the mode switch routes through the handlebar and connects into the left port of the cycle computer. After connecting the mode switch wire, tuck the excess wire back into the handlebar.

# EXPLODED VIEW

EXPLODED VIEW

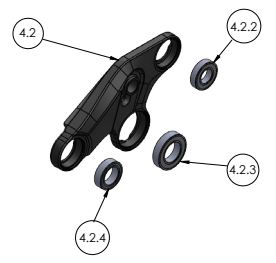
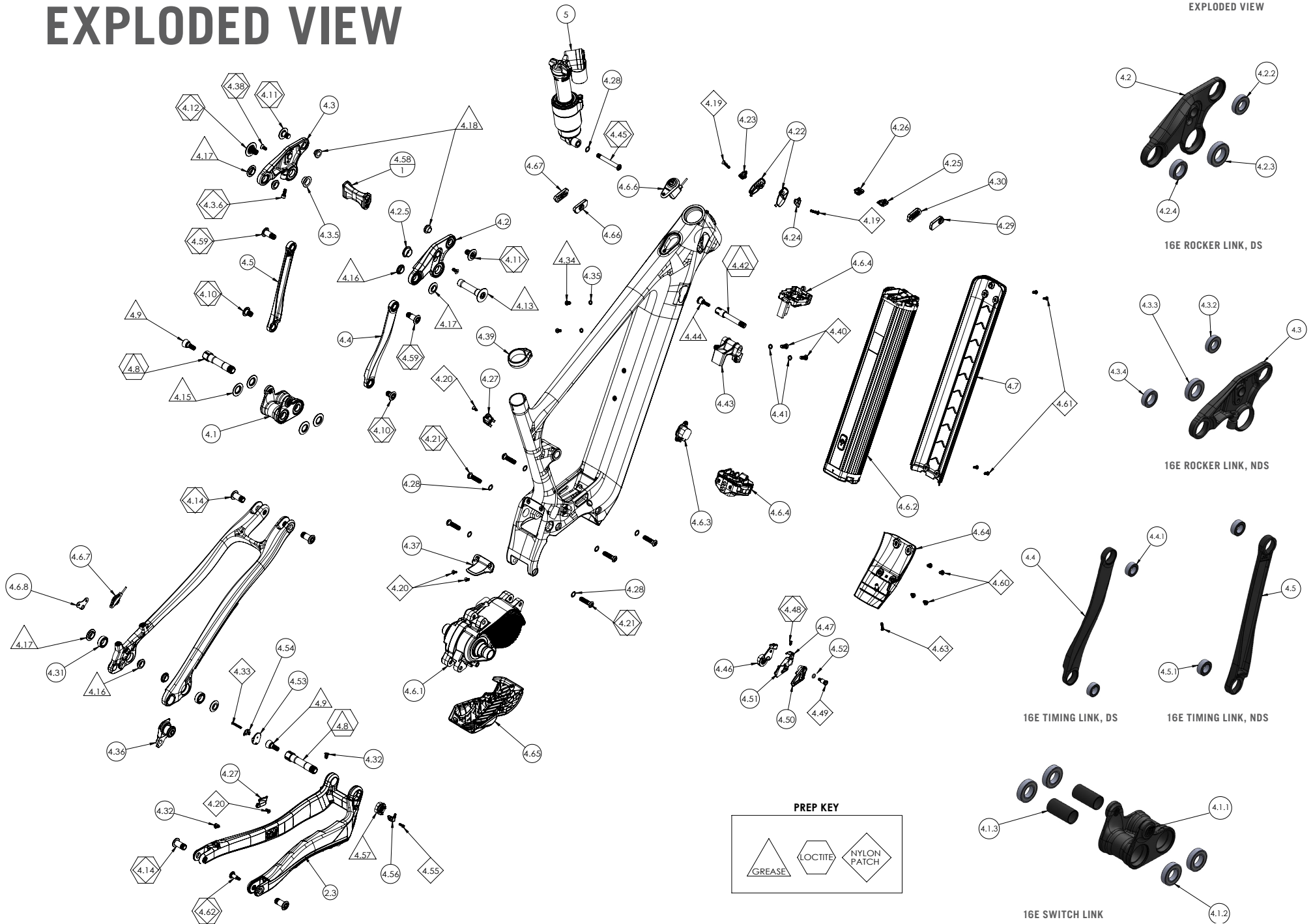

16E ROCKER LINK, DS

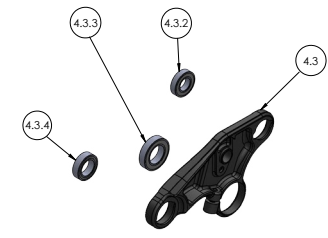

16E ROCKER LINK, NDS

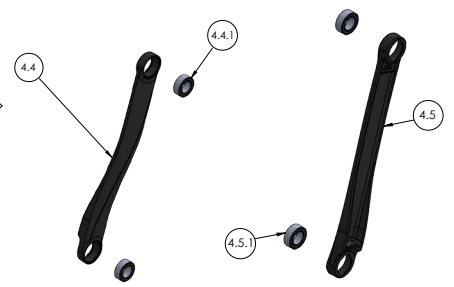

16E TIMING LINK, DS

16E TIMING LINK, NDS

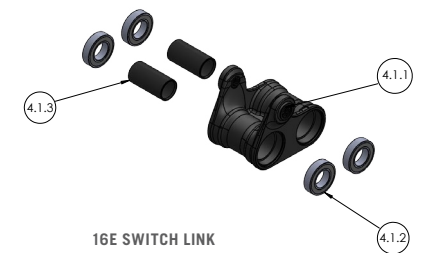

16E SWITCH LINK

**PREP KEY**

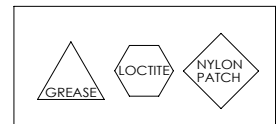

# 160E ASSEMBLY BILL OF MATERIAL

ITEM NO.	STOCK CODE	DESCRIPTION	UNIT QTY.
1	N/A	160E FRONT TRIANGLE ASSEMBLY	1
2	N/A	160E CHAINSTAY ASSEMBLY	1
2.2	400100218	160E CHAINGUARD - CS LOWER	1
2.3	400100219	160E CHAINGUARD - CS UPPER	1
3	N/A	160E SEATSTAY ASSEMBLY	1
3.2	400100217	160E CHAINGUARD - SS	1
4	N/A	160E SMALL PARTS ASSEMBLY	1
4.1	N/A	160E SWITCH LINK ASSEMBLY	1
4.1.1	300040526	160E SWITCH LINK	1
4.1.2	300020042	BEARING, 6902-2RS, 15 X 28 X 7	4
4.1.3	300030323	SPACER, 18 X 15.2 X 35.65L	2
4.2	N/A	160E ROCKER LINK DS ASSEMBLY	1
4.2.1	300040535	160E ROCKER LINK DS UPPER	1
4.2.2	300020056	ROCKER LINK BEARING, 6901-2RS, 12x24x6	1
4.2.3	300020001	BEARING, 6903-2RS, 17 X 30 X 7	1
4.2.4	HNA00000BA 00000000000	BEARING, 3802-2RS, 15 X 24 X 7	1
4.2.5	300030333	REDUCER, 15 X 17 X 2L, 24MM FLANGE	1
4.3	N/A	160E ROCKER LINK NDS ASSEMBLY	1
4.3.1	300040534	160E ROCKER LINK NDS UPPER	1
4.3.2	300020056	ROCKER LINK BEARING, 6901-2RS, 12x24x6	1
4.3.3	300020001	BEARING, 6903-2RS, 17 X 30 X 7	1
4.3.4	HNA00000BA 00000000000	BEARING, 3802-2RS, 15 X 24 X 7	1
4.3.5	300030333	REDUCER, 15 X 17 X 2L, 24MM FLANGE	1
4.3.6	300030168	SHCS, M5 X 0.8, 14L, BLACK	1
4.4	N/A	160E TIMING LINK - DS ASSEMBLY	1
4.4.1	300040527	160E TIMING LINK - DS	1
4.4.2	300020057	BEARING, 11197 LLU MAX, BO (11X19X7)	2
4.5	N/A	160E TIMING LINK - NDS ASSEMBLY	1
4.5.1	300040528	160E TIMING LINK - NDS	1
4.5.2	300020057	BEARING, 11197 LLU MAX, BO (11X19X7)	2

4.6	N/A	160E E-BIKE COMPONENTS KIT ASSEMBLY	1
4.6.1	N/A	MOTOR-DU-EP800	1
4.6.2	N/A	BATTERY-BTE8036, 630Wh	1
4.6.3	N/A	PORT-SATELLITE, SHIMANO EW-CP100	1
4.6.4	N/A	BATTERY MOUNT, BME8031A	1
4.6.6	N/A	SWITCH-SATELLITE, SHIMANO EW-SW300	1
4.6.7	N/A	SPEED SENSOR, SHIMANO EW-SS301	1
4.6.8	100190010	MAGNET MOUNT, WHEEL SPEED SENSOR, 30.5MM RADIUS	1
4.7	400100220	160E DT BATTERY GUARD	1
4.8	300030324	COLLET AXLE, 15MM X 69.25L, M15X1.5	2
4.9	300030334	COLLET WEDGE SUB-ASSEMBLY 15MM, M3 THREADED WEDGE BOLT	2
4.10	300030326	BOLT, M10X1.0X15, 11X6.5 SHOULDER	2
4.11	300030327	160E BOLT SHOCK M10X1	2
4.12	300030328	BOLT, MALE ROCKER, 15MM X 16.5L, M10X1.0	1
4.13	300030329	AXLE, LINK PIVOT, 15MM X 66.5L, M10X1	1
4.14	300030330	BOLT, CLEVIS, M12X1.0, 12 x 25.75L, M5 INTERNAL THREAD	4
4.15	300030347	INNER RACE EXTENSION 15MM MP	4
4.16	300030335	INNER RACE REDUCER 12/15MM, 3.5L. 21 FLANGE	4
4.17	300030336	INNER RACE REDUCER 12/15MM, 3.25L, 25 FLANGE	4
4.18	300030337	160E INNER RACE EXTENSION 10MM	2
4.19	300030175	SCREW, FH, M4 X 0.7, 20L	2
4.20	300030173	SCREW, FH, M4 X 0.7, 10L	4
4.21	300030359	SHOULDER BOLT, M8 X 1.25 X 33L	6
4.22	300040524	CABLE PORT COVER, HEAD TUBE, 2 PIECE	2
4.23	300040522	CLAMP, HT PORT DOUBLE, PA6	1
4.24	300040522	CLAMP, HT PORT SINGLE W/ E, PA6	1
4.25	300040522	CLAMP, HT PORT E ONLY, PA6	1
4.26	300040521	CLAMP, HT PORT SINGLE, PA6	1
4.27	300040518	COVER-CABLE PORT, SINGLE, RIGHT EXIT	2
4.28	300030069	WASHER 8.5 X 12.5 X 0.5 MM	7
4.29	300030350	SHOCK MOUNT CHIP, 160E, 25/35%, NONTHREADED	1
4.30	300030351	SHOCK MOUNT CHIP, 160E, 25/35%, THREADED	1
4.31	HNA00000BA 00000000000	BEARING, 3802-2RS, 15 X 24 X 7	2
4.32	300040533	GROMMET, 2.4 WIRE, 6.5 PORT	2

4.33	300030169	SCREW, FH, M3 X 0.5, 25L, SS, BLK OXIDE	1
4.34	300030170	SHCS, LOW PROFILE, M5 X 0.8, 10L	2
4.35	300030148	WASHER 5.1 X 8.9 X 1.0 MM	2
4.36	300060080	SRAM UNIVERSAL HANGER	1
4.37	400100216	160E ST FENDER	1
4.38	300030355	SHCS, FLAT HEAD, M5 X 0.8 X 14	2
4.39	300060078	YETI SEAT CLAMP, BOLT ON, 31.6	1
4.45	300030360	SHOULDER BOLT, M8 X 1.25 X 63L	1
4.46	300030352	COLLET NUT, M15X1.5, KEYED, CHAINGUIDE MOUNT	1
4.47	300030339	HOUSING CLAMP, GUIDE/COLLET NUT MOUNT	1
4.48	300030353	FHCS, M3 X 0.5, 8L, SS, BLK OXIDE	1
4.49	300030398	SHOULDER BOLT, M5 X 0.8, CHAIN GUIDE MOUNT	1
4.50	N/A	OUTER GUIDE, ONEUP COMPONENTS, 2019-PRESENT	1
4.51	N/A	INNER GUIDE, ONEUP COMPONENTS, 2019-PRESENT	1
4.52	N/A	O-RING, CHAIN GUIDE, 10MM OD X 1.8MM THICK	1
4.53	300030343	BASE, HOUSING CLAMP, CS COLLET HEAD	1
4.54	300030344	CLAMP, HOUSING CLAMP, CS COLLET HEAD	1
4.55	300030354	SHCS, M3 X 0.5, 10L, SS, BLK OXIDE	1
4.56	300030340	CLAMP, CS COLLET NUT, 160E	1
4.57	300030345	COLLET NUT, M15X1.5, KEYED, CABLE CLAMP	1
4.58	300040536	160E BRIDGE - UPPER LINK	1
4.59	300030325	SHOULDER SCREW, 11MM X 27L, M10 X 1.0X10.5L THREAD, ALLOY	2
4.60	300030171	BHCS, M5 X 0.8 X 8L	4
4.61	300030313	BHCS, M4 X 0.7 X 10L	4
4.62	300030332	SHOULDER SCREW, STEPPED, 7.5 X 21.5L, M5 X 0.8, ALUMINUM	1
4.63	300030356	BHCS, M3 X 0.5 X 18L	1
4.64	400100221	160E LOWER DT GUARD - MEDIUM	1
4.65	N/A	MOTOR COVER, SHIMANO DC-EP800, LOWER	1
4.66	300030348	SHOCK MOUNT CHIP, 160E, 30%, NONTHREADED	1
4.67	300030349	SHOCK MOUNT CHIP, 160E, 30%, THREADED	1
5	N/A	160E SHOCK ASSEMBLY	1

# REBUILD KITS

<b>200020390</b>	<b>160E MASTER REBUILD KIT 2022-current</b>	<b>1</b>
300020042	BEARING, 6902-2RS, 15 X 28 X 7	4
300030323	SPACER, 18 X 15.2 X 35.65L	2
300020056	BEARING, 6901-2RS, 12x24x6	2
300020001	BEARING, 6903-2RS, 17 X 30 X 7	2
HNA00000BA 0000000000	BEARING, 3802-2RS, 15 X 24 X 7w	4
300030333	REDUCER, 15 X 17 X 2L, 24MM FLANGE	2
300030168	SHCS, M5 X 0.8, 14L, BLACK	1
300020057	BEARING, 11197 LLU MAX, BO (11X19X7)	4
300030324	COLLET AXLE, 15MM X 69.25L, M15X1.5	2
300030334	COLLET WEDGE SUB-ASSEMBLY 15MM, M3 THREADED WEDGE BOLT	2
300030326	BOLT, M10X1.0X15, 11X6.5 SHOULDER	2
300030327	160E BOLT SHOCK M10X1	2
300030328	BOLT, MALE ROCKER, 15MM X 16.5L, M10X1.0	1
300030329	AXLE, LINK PIVOT, 15MM X 66.5L, M10X1	1
300030330	BOLT, CLEVIS, M12X1.0, 12 x 25.75L, M5 INTERNAL THREAD	4
300030347	INNER RACE EXTENSION 15MM MP	4
300030335	INNER RACE REDUCER 12/15MM, 3.5L. 21 FLANGE	4
300030336	INNER RACE REDUCER 12/15MM, 3.25L, 25 FLANGE	4
300030337	160E INNER RACE EXTENSION 10MM	2
300030175	SCREW, FH, M4 X 0.7, 20L	2
300030173	SCREW, FH, M4 X 0.7, 10L	4
300030359	SHOULDER BOLT, M8 X 1.25 X 33L	6
300040524	CABLE PORT COVER, HEADTUBE, 2 PIECE	2
300040522	CLAMP, HT PORT DOUBLE, PA6	1
300040529	CLAMP, HT PORT SINGLE W/ E, PA6	1
300040530	CLAMP, HT PORT E ONLY, PA6	1
300040521	CLAMP, HT PORT SINGLE, PA6	1
300040518	COVER-CABLE PORT, SINGLE, RIGHT EXIT	2
300030069	WASHER 8.5 X 12.5 X 0.5 MM	7
300030350	SHOCK MOUNT CHIP, 160E, 25/35%, NONTHREADED	1

300030351	SHOCK MOUNT CHIP, 160E, 25/35%, THREADED	1
300040533	GROMMET, 2.4 WIRE, 6.5 PORT	2
300030169	SCREW, FH, M3 X 0.5, 25L, SS, BLK OXIDE	1
300030170	SHCS, LOW PROFILE, M5 X 0.8, 10L	2
300030148	WASHER 5.1 X 8.9 X 1.0 MM	2
300030355	SHCS, FLAT HEAD, M5 X 0.8 X 14	2
300030214	WASHER 6.3 X10.0 X 1.0 MM	2
300030346	COLLET AXLE, LONG HEAD, M10X1.0	1
300030338	COLLET WEDGE SUB-ASSEMBLY 10MM, TALL WEDGE BOLT	1
300030360	SHOULDER BOLT, M8 X 1.25 X 63L	1
300030352	COLLET NUT, M15X1.5, KEYED, CHAINGUIDE MOUNT	1
300030339	HOUSING CLAMP, GUIDE/COLLET NUT MOUNT	1
300030353	FHCS, M3 X 0.5, 8L, SS, BLK OXIDE	1
300030342	SHOULDER BOLT, M5 X 0.8, CHAIN GUIDE MOUNT	1
300030343	BASE, HOUSING CLAMP, CS COLLET HEAD	1
300030344	CLAMP, HOUSING CLAMP, CS COLLET HEAD	1
300030354	SHCS, M3 X 0.5, 10L, SS, BLK OXIDE	1
300030340	CLAMP, CS COLLET NUT, E160	1
300030345	COLLET NUT, M15X1.5, KEYED, CABLE CLAMP	1
300030325	SHOULDER SCREW, 11MM X 27L, M10 X 1.0X10.5L THREAD, ALLOY	2
300030171	BHCS, M5 X 0.8 X 8L	4
300030313	BHCS, M4 X 0.7 X 10L	4
300030332	SHOULDER SCREW, STEPPED, 7.5 X 21.5L, M5 X 0.8, ALUMINUM	1
300030356	BHCS, M3 X 0.5 X 18L	1
300030348	SHOCK MOUNT CHIP, 160E, 30%, NONTHREADED	1
300030349	SHOCK MOUNT CHIP, 160E, 30%, THREADED	1
<b>200020391</b>	<b>160E HARDWARE REBUILD KIT 2022-current</b>	<b>1</b>
300030323	SPACER, 18 X 15.2 X 35.65L	2
300030333	REDUCER, 15 X 17 X 2L, 24MM FLANGE	2
300030168	SHCS, M5 X 0.8, 14L, BLACK	1
300030324	COLLET AXLE, 15MM X 69.25wL, M15X1.5	2

300030334	COLLET WEDGE SUB-ASSEMBLY 15MM, M3 THREADED WEDGE BOLT	2
300030326	BOLT, M10X1.0X15, 11X6.5 SHOULDER	2
300030327	160E BOLT SHOCK M10X1	2
300030328	BOLT, MALE ROCKER, 15MM X 16.5L, M10X1.0	1
300030329	AXLE, LINK PIVOT, 15MM X 66.5L, M10X1	1
300030330	BOLT, CLEVIS, M12X1.0, 12 x 25.75L, M5 INTERNAL THREAD	4
300030347	INNER RACE EXTENSION 15MM MP	4
300030335	INNER RACE REDUCER 12/15MM, 3.5L, 21 FLANGE	4
300030336	INNER RACE REDUCER 12/15MM, 3.25L, 25 FLANGE	4
300030337	160E INNER RACE EXTENSION 10MM	2
300030175	SCREW, FH, M4 X 0.7, 20L	2
300030173	SCREW, FH, M4 X 0.7, 10L	4
300030359	SHOULDER BOLT, M8 X 1.25 X 33L	6
300040524	CABLE PORT COVER, HEAD TUBE, 2 PIECE	2
300040522	CLAMP, HT PORT DOUBLE, PA6	1
300040529	CLAMP, HT PORT SINGLE W/ E, PA6	1
300040530	CLAMP, HT PORT E ONLY, PA6	1
300040521	CLAMP, HT PORT SINGLE, PA6	1
300040518	COVER-CABLE PORT, SINGLE, RIGHT EXIT	2
300030069	WASHER 8.5 X 12.5 X 0.5 MM	7
300030350	SHOCK MOUNT CHIP, 160E, 25/35%, NONTHREADED	1
300030351	SHOCK MOUNT CHIP, 160E, 25/35%, THREADED	1
300040533	GROMMET, 2.4 WIRE, 6.5 PORT	2
300030169	SCREW, FH, M3 X 0.5, 25L, SS, BLK OXIDE	1
300030170	SHCS, LOW PROFILE, M5 X 0.8, 10L	2
300030148	WASHER 5.1 X 8.9 X 1.0 MM	2
300030355	SHCS, FLAT HEAD, M5 X 0.8 X 14	2
300030214	WASHER 6.3 X10.0 X 1.0 MM	2
300030346	COLLET AXLE, LONG HEAD, M10X1.0	1
300030338	COLLET WEDGE SUB-ASSEMBLY 10MM, TALL WEDGE BOLT	1
300030360	SHOULDER BOLT, M8 X 1.25 X 63L	1
300030352	COLLET NUT, M15X1.5, KEYED, CHAINGUIDE MOUNT	1
300030339	HOUSING CLAMP, GUIDE/COLLET NUT MOUNT	1
300030353	FHCS, M3 X 0.5, 8L, SS, BLK OXIDE	1

300030398	SHOULDER BOLT, M5 X 0.8, CHAIN GUIDE MOUNT	1
300030343	BASE, HOUSING CLAMP, CS COLLET HEAD	1
300030344	CLAMP, HOUSING CLAMP, CS COLLET HEAD	1
300030354	SHCS, M3 X 0.5, 10L, SS, BLK OXIDE	1
300030340	CLAMP, CS COLLET NUT, E160	1
300030345	COLLET NUT, M15X1.5, KEYED, CABLE CLAMP	1
300030325	SHOULDER SCREW, 11MM X 27L, M10 X 1.0X10.5L THREAD, ALLOY	2
300030171	BHCS, M5 X 0.8 X 8L	4
300030313	BHCS, M4 X 0.7 X 10L	4
300030332	SHOULDER SCREW, STEPPED, 7.5 X 21.5L, M5 X 0.8, ALUMINUM	1
300030356	BHCS, M3 X 0.5 X 18L	1
300030348	SHOCK MOUNT CHIP, 160E, 30%, NONTHREADED	1
300030349	SHOCK MOUNT CHIP, 160E, 30%, THREADED	1
200020392	<b>160E PROTECTOR KIT 2022-current</b>	1
400100218	CHAINGUARD, CS LOWER, 160E	1
400100219	CHAINGUARD, CS UPPER, 160E	1
400100217	CHAINGUARD, SS, 160E	1
200020404	<b>160E BEARING REBUILD KIT 2022-current</b>	1
300020042	BEARING, 6902-2RS, 15 X 28 X 7	4
300020056	BEARING, 6901-2RS, 12x24x6	2
300020001	BEARING, 6903-2RS, 17 X 30 X 7	2
HNA00000BA 00000000000	BEARING, 3802-2RS, 15 X 24 X 7	4
300020057	BEARING, 11197 LLU MAX, BO (11X19X7)	4
200020396	<b>160E CABLE PORT KIT 2022-current</b>	1
300040524	CABLE PORT COVER, HEAD TUBE, 2 PIECE	2
300040522	CLAMP, HT PORT DOUBLE, PA6	1
300040529	CLAMP, HT PORT SINGLE W/ E, PA6	1
300040530	CLAMP, HT PORT E ONLY, PA6	1
300040521	CLAMP, HT PORT SINGLE, PA6	1
300040518	COVER-CABLE PORT, SINGLE, RIGHT EXIT	2

300040533	GROMMET, 2.4 WIRE, 6.5 PORT	2
300030173	SCREW, FH, M4 X 0.7, 10L	2
300030175	SCREW, FH, M4 X 0.7, 20L	2
300030169	SCREW, FH, M3 X 0.5, 25L, SS, BLK OXIDE	1
300030343	BASE, HOUSING CLAMP, CS COLLET HEAD	1
300030344	CLAMP, HOUSING CLAMP, CS COLLET HEAD	1
300030339	HOUSING CLAMP, GUIDE/COLLET NUT MOUNT	1
300030353	FHCS, M3 X 0.5, 8L, SS, BLK OXIDE	1
200020397	<b>160E BATTERY GUARD - ALL SIZES 2022-current</b>	1
400100220	BATTERY GUARD, 160E DT	1
300030313	BHCS, M4 X 0.7 X 10L, STAINLESS, BLACK	4
200020398	<b>160E LOWER DOWNTUBE GUARD - LARGE 2022-current</b>	1
400100223	LOWER GUARD, 160E, LARGE, DT	1
300030171	BHCS, M5 X 0.8 X 8L, STAINLESS, BLACK	4
300030356	BHCS, M3 X 0.5 X 18L, STAINLESS, BLACK	1
200020399	<b>160E LOWER DOWNTUBE GUARD - MEDIUM 2022-current</b>	1
400100221	LOWER GUARD, 160E, MEDIUM, DT	1
300030171	BHCS, M5 X 0.8 X 8L, STAINLESS, BLACK	4
300030356	BHCS, M3 X 0.5 X 18L, STAINLESS, BLACK	1
200020400	<b>160E LOWER DOWNTUBE GUARD - SMALL 2022-current</b>	1
400100222	LOWERCARD, 160E, SMALL, DT	1
300030171	BHCS, M5 X 0.8 X 8L, STAINLESS, BLACK	4
300030356	BHCS, M3 X 0.5 X 18L, STAINLESS, BLACK	1
200020401	<b>160E LOWER DOWNTUBE GUARD - XL 2022-current</b>	1
400100224	LOWER GUARD, 160E, XL, DT	1
300030171	BHCS, M5 X 0.8 X 8L, STAINLESS, BLACK	4
300030356	BHCS, M3 X 0.5 X 18L, STAINLESS, BLACK	1

<b>160E MOTOR COVER - ALL SIZES 2022-current</b>		
100190016	MOTOR COVER, SHIMANO DC-EP800, LOWER	1
<b>160E WHEEL SPEED SENSOR 2022-current</b>		
100190010	MAGNET MOUNT, WHEEL SPEED SENSOR, 30.5MM RADIUS	1
400100227	160E FRAME PROTECTOR SHEET GLOSS	1
400100228	160E FRAME PROTECTOR SHEET MATTE	1
300060080	SRAM UNIVERSAL HANGER	1



# ADDITIONAL INFORMATION

- To prevent the unauthorized use of your e-bike, secure the bike with a lock or remove the battery when not in use.
- Full suspension bikes have many moving parts. Caution should be used to avoid pinch points when operating or performing any maintenance on the bike.
- This bike is only intended for one user at a time. Additional users are not permitted on this bike.
- Baggy clothing should be avoided while riding this bike as excessively baggy clothing can get caught in chain.
- This bike should not be used to tow any cargo or trailers.
- The 160E is not equipped with any lighting equipment needed for nighttime riding. We can only recommend daytime operation.
- If riding in traffic, the use of a bell is strongly recommended.
- The 160E is rated to a max system weight of 130Kg and an ASTM 4 rating. Riding in higher numbered conditions increases the forces on the bicycle and the risk of injury to the rider.
- The water bottle mounting location is only designed to fit a traditional water bottle cage and bottle. Bolting any other item than what is prescribed above could result in frame damage.
- Be advised, use of a mountain bike will result in vibrations that will be transmitted to the rider. This is inherent to the sport and cannot be avoided.

## STORAGE

- Make sure your bike is stored in an area that is free from hazardous conditions that could damage the bike or cause an obstruction. Extreme heat or cold should be avoided and any machinery that emits ozone or exhaust should not be near your bike when stored.
- Avoid wet conditions that can cause corrosion in certain metal alloys. UV light can damage or degrade bicycle components and should be avoided during storage.
- Properly service your bike prior to long term storage and when riding the first time after storage. See maintenance schedule in this manual for guidance.

## TRANSPORT

Safe transport is critical for protecting the bicycle frame and its components from damage. Bikes can be awkward to lift, and proper lifting techniques should be used when loading or unloading your bike. Packing your bike should be done by a certified bike mechanic when possible. The use of a hard bike case is recommended for the highest level of protection. If the wheels are removed for transport, make sure the area where the hub and axle were in the fork and rear triangle is sufficiently supported to avoid damage. If transported inside a vehicle, make sure all parts of the bike that contact the vehicle are padded properly. When transporting on the outside of the vehicle, make sure the bike is not exposed to hot exhaust or debris that can impact the bike while moving.

## CLEANING

The best way to wash your bike is with a soft brush and rag, using soapy water or a mild cleaner such as Motorex Bike Clean or equivalent. Do not use harsh detergents or directly pressure wash any of the bearings, hardware or seals.

## BATTERY SAFETY

- The Shimano battery is waterproof but do not submerge it in water or directly spray any electronic components with water – If the battery becomes damaged it must not be charged, used, or transported.
- In case of a battery fire, only use class D fire extinguisher to extinguish the flames.
- Only charge the battery with certified Shimano STEP's battery chargers.
- Only use the approved Shimano battery in the bicycle.
- See STEPS user manual for further safety information.  
<https://www.shimanosteps.com/>
- Call2Recycle.com has created a program to recycle E bike batteries once they are at the end of their life. For more information, contact your dealer or visit <https://www.call2recycle.org/e-bikes/> to find your closest recycling drop off location.

**WARNING:** Used batteries and electronic equipment may contain harmful substances which, if not properly disposed of, could damage the environment and your health. Additionally, batteries and electronics may contain important raw minerals, which can be recycled. For this reason, you must not dispose of electrical components with household waste, but must return them after use to a specialty store, at a municipal collection point or at your nearest authorized Yeti Cycle dealer.

## WHAT IS SIXFINITY TECHNOLOGY AND HOW DOES IT WORK?

Sixfinity is a 6-bar linkage suspension platform that allows kinematics and chassis structure to be tuned for the specific demands, and packaging constraints of an E bike.

At its core, Sixfinity exhibits many underlying behaviors of Switch Infinity, but with intentional variations to account for the fundamental dynamic differences that come with the addition of a drive unit and battery.

Like Switch Infinity, Sixfinity's lower Switch link first moves upward, and then switches directions and travels downward as the suspension moves from the extended to compressed states. As a result, Sixfinity has a similar anti-squat profile proven with Switch Infinity. However, due to the drive unit assist, the magnitude of the profile is reduced to bias the acceleration response towards increased traction.

The Sixfinity anti-rise profile is consistent across the entire travel range, similar to Switch Infinity. However, the magnitude is reduced to bias the deceleration response towards increased traction for a composed and predictable performance and chassis geometry while braking, even with the added mass of a drive unit and battery.

Sixfinity's leverage rate curve is linear and progressive. However, the progressivity is both increased and adjustable to be tailored to one's specific riding style, trail conditions or shock preference.

## DOES THE SIXFINITY SYSTEM REQUIRE MAINTENANCE?

The Sixfinity system utilizes a series of links that rotate on fully sealed bearings. The pivot interfaces utilize floating collet and bearing assemblies designed for durability and minimizing friction. We recommend checking the entire bike monthly for loose bolts, including the Sixfinity system. Bearing service intervals can vary depending on climate, trail conditions and riding frequency. For more information about this system and general bicycle maintenance, please consult the 160E user manual or contact your nearest authorized Yeti Cycles dealer.

## CAN I REPLACE OR MODIFY ANY YETI FRAME PARTS ON MY 160E?

All replacement frame parts for your 160E can be found through your local dealer or on our webstore. Only genuine Yeti parts should be used when replacing any parts on your frame. We know there are a lot of aftermarket products out there that seem legit but we do not have the ability to qualify and ensure all of these products are safe to use on our frames. If it is found that any frame part has been modified or replaced all warranties will be voided and all liability will be assumed by the customer.

## CAN I CHANGE OR UPGRADE THE SPEC COMPONENTS ON MY 160E?

There are many options in aftermarket parts to upgrade or personalize your bike. Some parts are standardized, especially from the big brands like Fox, Shimano, SRAM etc. You should always confirm with a professional mechanic that your parts are the correct standard and correctly and securely mount to your bike without any interference or play. Pay special attention to all the bike's standards and check the fit before use.

## CAN I USE AN ANGLESET ON THE 160E?

The 160E was designed with an integrated headset which has the headset cups molded into the frame so you can easily drop the bearings into the cups. There are some aftermarket angle-sets available for this style headset however the frame was not tested for the use of these and therefore should not be used. Yeti's warranty will be voided if it is found an angleset was installed on the frame and all liability will be assumed by the customer. See "What travel fork is the 160E designed to use" for more information. A71

## WHAT TRAVEL FORK IS THE 160E DESIGNED TO USE?

The 160E is designed to run a 170mm travel fork. We test our frames to 20mm over the spec fork. So if you're feeling the need to beef up the fork you can run up to a 190mm fork no problem. It will slacken the head angle and seat tube angle and raise the bottom bracket. Running a shorter fork is fine too if that suits you. Shortening the fork will steepen the head angle and seat tube angle and lower the bottom bracket For more geometry information, check out the geometry section.

## HOW BIG OF A TIRE CAN I FIT ON THE 160E?

The short answer is the 160E can accept up to a 2.6" tire. There is great tire clearance on the 160E but tire sizes vary widely by manufacturers, so it is hard to give a number that works for all brands.

## CAN I FIT A WATER BOTTLE INSIDE THE FRONT TRIANGLE?

Yes, we designed the 160E to accommodate a standard sized water bottle inside the front triangle with a piggy-back shock. We recommend using a side-entry cage for easiest access. The SM size is the one exception and will only fit small volume water bottles.

## WHAT CRANKS AND BOTTOM BRACKET CAN I USE ON THE 160E?

The 160E uses the EP8 drive unit which replaces the BB interface. The crank spindle is build into the drive until and all you have to do is bolt on any Shimano EP8 compatible crank arm.

## WHAT REAR WHEEL AXLE FITS ON MY 160E?

The 160E is designed to work exclusively with SRAM's Universal Derailleur Hanger at 12x148mm spacing. This axle had a thread pitch 12x1.0. Note that this axle is only compatible with frames specifically designed with the Universal Derailleur Hanger.

## WHAT TYPE OF HEADSET DOES THE 160E USE?

The 160E uses an Integrated 41mm/52mm tapered headset. This system allows for the headset bearings to be contained inside the head tube for an overall lower ride height, more simplified installation, and increased stiffness.

**HOW BIG OF A ROTOR WILL FIT ON THE FRAME?**

The 160E has a direct mount rear brake tab and can run a 180mm rotor without the need for a brake adaptor. With the use of a brake adaptor the frame can accept up to a 220mm rotor.

**CAN I RUN A STEALTH SEATPOST DROPPER ON THE 160E?**

Yes. The 160E has routing options for stealth only.

**WHAT CHAINLINE WAS THE 160E DESIGNED AROUND?**

The 160E was designed around a 53mm and 55mm Boost chainline.

**WHAT IS THE MAX SIZE SINGLE-CHAINRING THAT FITS ON THE 160E?**

The 160E will only accept a 34t round ring.

**DOES THE 160E HAVE ISCG MOUNTS?**

No. The 160E has a custom top guide mount that is designed to work with the OneUp top guide.

**WHAT TYPE OF SHOCK DOES THE 160E USE?**

The 160E uses a 205 x 65mm Trunnion shock. Depending on the shock model, it can be locked out but we recommend running it fully open for the best compliance and traction.

**WHAT TYPE OF SHOCK HARDWARE DOES THE 160E USE?**

The 160E uses custom hardware on both sides of the shock. The lower shock hardware is adjustable so that you can tune the leverage rate to suit your riding style or terrain you are riding. Please see the owners manual for further information.

**CAN I PUT A COIL SHOCK ON MY 160E?**

Yes, the 160E is designed to be compatible with both air and coil-sprung shocks. We would suggest going to a higher rate on the rate chip as coil sprung shocks typically work the best at higher leverage rates.

**WHAT PERCENTAGE SAG DO YOU RECOMMEND FOR THE 160E?**

We would advise starting with 30% sag, or 19.5mm of shock stroke for optimal pedaling efficiency and terrain compliance. Be sure to set your sag at your normal riding weight, gear included. Feel free to venture slightly above or below 30% to suit your personal preference. Visit our shock set up page to help set up your suspension, <https://shocksetup.yeticycles.com/calculator>.

**WHAT SIZE SEAT POST DOES THE 160E USE?**

The 160E uses a 31.6mm seat post.

**WHAT SIZE SEAT COLLAR DOES THE 160E USE?**

The 160E uses a 36.4mm seat collar.

**WHAT IS THE WARRANTY ON MY 160E?**

The 160E has a LIFETIME manufacturer's warranty.

**WHAT IS THE LONGEST TRAVEL DROPPER POST I CAN RUN ON THE 160E?**

This is mostly defined by your inseam. You can run any travel as long as you are above the minimum insert mark and you are not so low your tire rubs on your saddle or your dropper bottoms out in the frame. Your local Yeti dealer can help you sort this out.

**CAN I CONVERT THIS BIKE INTO A "MULLET" BIKE AND PUT A 27.5" WHEEL ON?**

It is possible, but we would not suggest it as it would lower your BB too much and slacken your head tube angle and seat tube angle. But hey, if those changes suit your ride style then go for it.

**WHAT HEADSET TOP CAP DOES THE 160E USE?**

The 160E uses a 51mm top cap rather than the standard cap diameter. We use this larger cap because the 160E is tested to Yeti's more rigorous DH test standards which require a larger HT wall thickness.

**WHY WOULD I WANT TO ADJUST THE LEVERAGE RATE OF THE 160E?**

Your personal preference, riding style, and terrain can influence which leverage rate setting you choose on your 160E. The best thing to do is experiment and see what works best for you. The 'stock' setting is 30% and should be a great place to start. For more information about leverage rates visit our shock setup page, <https://www.yeticycles.com/bikes/160e/?guide:support-shock-setup>

**WHAT IF I ENCOUNTER AN ERROR CODE ON MY E160?**

If you encounter an error code on your 160E, please visit the following link for troubleshooting tips. Check out the E-Tube FAQs at this link- <https://bike.shimano.com/en-EU/e-tube/project.html>

**CAN I CHANGE OR SERVICE ANY OF THE ELECTRICAL PARTS?**

No parts or mounts should be service unless by a certified shop.

**WHAT IS THE RANGE OF THE BATTERY?**

The battery capacity on your 160E is 630 Watt Hours. Many factors influence range; weight, location, gradient, selected mode, ambient temperature, etc. The range function on the display unit will give you the best estimate.

**CAN I RUN A DIFFERENT SIZE BATTERY IN THE 160E?**

No. The 160E is designed to be compatible with the BT-E8036 Shimano 630Wh battery only.

**HOW DO I GET A SPARE BATTERY?**

From Shimano - BT-E8036. Spare battery covers are also available on our website or at your local Yeti Cycles dealer.

**CAN I RIDE WITHOUT A BATTERY IN MY BIKE?**

No. The downtube cover is attached to the battery, without it you are exposing internal frame and electrical components to damage.

**WHAT DO I DO IF I LOOSE POWER WHILE RIDING?**

The 160E can still be pedaled without the battery/motor active. If the loss of power wasn't due to a depleted battery, first try turning it off and back on again. If the problem persists, contact customer service.

**HOW DO I TAKE MY 160E ON A PLANE?**

160E is spec'd with a 630Wh battery. This size battery is typically larger than what is allowed on a plane. We advise checking your local regulations prior to flying.

**HOW DO I UPDATE THE FIRMWARE ON MY 160E?**

Detailed firmware update instructions are located on the Shimano STEPS app or software.

**HOW DO I CONNECT MY PHONE OR MOBILE DEVICE TO THE SHIMANO STEPS SYSTEM?**

Power the system on, go to the Bluetooth-LE menu on the display by pressing the button on the bottom of the display and connect via the E-tube app.

**WHERE DO I GET MY 160E SERVICED?**

Any authorized Yeti Cycles dealer. Find your nearest dealer via our dealer locator.  
<https://yeticycles.com/dealers>

**HOW DO I REPAIR MY 160E ON THE TRAIL?**

The 160E uses Shimano STEPS for the drive unit so no special tools are required.

**ARE THE ELECTRONICS WATERPROOF?**

The Shimano STEPS system is water-resistant and the 160E frame is designed to drain water. Full submersion and power washing is not recommended.

**CAN I RUN A DUAL CROWN FORK ON THE 160E?**

Yes. 190mm is the maximum recommended fork travel for the 160E.

**HOW DO I DISPOSE OF THE 160E BATTERY?**

The 160E battery cannot be disposed of with traditional garbage. Please talk to your authorized Yeti Cycles dealer or reference the 160E manual for information about proper disposal of the battery.

**CAN I RUN A SRAM DRIVETRAIN WITH MY SHIMANO MOTOR ON THE 160E?**

The 160E is fully compatible with SRAM drivetrains. There are a couple of things to keep in mind.

- 1) You will need to use the stock Shimano chainring spider that comes on the bike. This part is designed to interface with the EP8 drive unit spindle and all you will have to do is remove the chainring bolts and replace the chainring with a SRAM 104 BCD 34 tooth chainring. The 160E is only compatible with 34 tooth chainrings.
- 2) The crankarms will not need to be replaced but we do recommend replacing the complete drivetrain, including derailleur, shifter, cassette, chain, and chainring. Mixing components may cause undesirable shifting performance.

**CAN I RECYCLE MY BATTERY?**

Yes, currently you can recycle your battery in the US and Canada through Call 2 Recycle. For more information about the program please visit, <https://www.call2recycle.org/e-bikes/> or to find the nearest drop off location please visit, <https://www.call2recycle.org/locator/>, and select the E-Bike Battery check box. If you are outside the US or Canada check your local regulations for how to properly recycle your ebike battery. <https://www.call2recycle.org/e-bikes/>

**WHY IS MY DEALER CHARGING ME AN EXTRA \$15 FOR BATTERY RECYCLING IN THE US AND CANADA?**

Your dealer will be charging you a recycling fee when you purchase your bike. In the US this fee is \$15, in Canada it will vary by province between \$5 CAD and \$15 CAD. This fee funds the ebike battery recycling program through People 4 Bikes and Call 2 Recycle. When your battery is at the end of its life, bring it back to the shop where you purchased your bike or any of the other certified drop off sites listed on the call 2 Recycle site. It will then be sent to one of the many Call 2 Recycle sites for processing and conversion back into a brand new battery. Visit the Call 2 Recycle site for more information.

# LIFETIME WARRANTY

## HERE'S EVERYTHING YOU NEED TO KNOW ABOUT OUR LIFETIME WARRANTY:

All 2019 (or newer) frames, including the Switch Infinity, are covered for life against damage due to manufacturing defects for the original purchaser. Paint and finish are covered for 1-year. We will repair or replace, at our discretion, any frame we deem defective. There are a few conditions: you must register it online at [yeticycles.com](http://yeticycles.com) and you must take it to an authorized Yeti Cycles dealer for processing. Warranty does not cover damage due to ordinary wear and tear, neglect or intentional destruction. From a slingshot or your truck.

If you happen to have a crash or non-warranty situation, we'll get you back on the trail with a reasonable replacement price. Same conditions as above.

Lifetime Warranty applies to all 2019 and newer frames (including the SB100). Model year 2018 and older frames will be covered under our previous warranty (5-year or 2-year based on time of purchase).

Simple as that. No fine print.

## DISCLAIMER

YETI Cycles is not responsible for any damages to you or others arising from riding, transporting or other use of your bicycle. In the event that your frame breaks or malfunctions, YETI Cycles shall have no liability or obligation beyond the repair or replacement of your frame pursuant to the terms outlined in the warranty.

\*If you have a warranty concern, please contact your authorized Yeti Cycles dealer.

## YETI CYCLES

621 Corporate Circle, Unit

B Golden, CO 80401

(p) 303-278-6909

(f) 303-278-6906

[yeticycles.com](http://yeticycles.com)

## BUSINESS HOURS

Monday-Friday

8AM-11:30AM

1:00PM-5:30PM (MST)

EPAC ACCORDING TO EN 15194  
CUT OFF SPEED: 20 MPH / 25 KM/H  
MAX POWER: 0.25 KW  
MAX PERMISSIBLE SYSTEM WEIGHT: 130 KG  
CONFIGURATION WEIGHT: 22.45 KG  
MODEL NAME: 160E  
YEAR OF CONSTRUCTION: 2021, 2022



# ASTM

## STANDARD CLASSIFICATION FOR BICYCLE USAGE

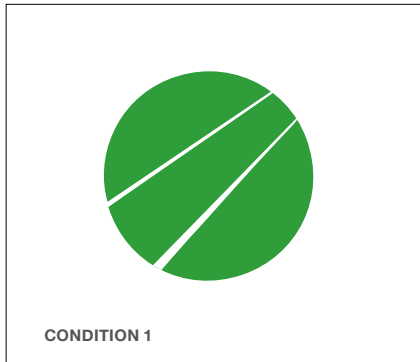

This is a set of conditions for the operation of a bicycle on a regular paved surface where the tires are intended to maintain ground contact.

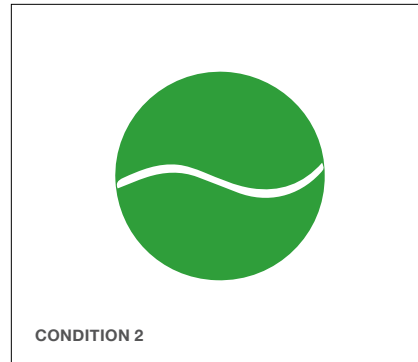

This is a set of conditions for the operation of a bicycle that includes Condition 1 as well as unpaved and gravel roads and trails with moderate grades. In this set of conditions, contact with irregular terrain and loss of tire contact with the ground may occur. Drops are intended to be limited to 15 cm (6 in.) or less.



This is a set of conditions for operation of a bicycle that includes Condition 1 and Condition 2 as well as rough trails, rough unpaved roads, and rough terrain and unimproved trails that require technical skills. Jumps and drops are intended to be less than 61 cm (24 in.).



This is a set of conditions for operation of a bicycle that includes Conditions 1, 2, and 3, or downhill grades on rough trails at speeds less than 40 km/h (25 mph), or both. Jumps are intended to be less than 122 cm (48 in.).



This is a set of conditions for operation of a bicycle that includes Conditions 1, 2, 3, and 4; extreme jumping; or downhill grades on rough trails at speeds in excess of 40 km/h (25 mph); or a combination thereof.

**EU DECLARATION OF CONFORMITY**

## Manufacturer:

Yeti Cycling, LLC (d.b.a. Yeti Cycles)  
621 Corporate Circle, Unit B, Golden, CO 80401 USA

## EU Authorized representative:

Globalnorm GmbH  
Kurfuerstenstr. 112  
10787 Berlin  
Germany  
team.compliance@globalnorm.de  
Phone: +49 30 3229027-50

Product name(s): Yeti Cycles  
Product model(s): 160E  
Serial number range: 1AIFD010000-6LIRD619999

The object of the declaration described above is in conformity with the relevant Union harmonization legislation:

- Directive 2006/42/EC of the European Parliament and of the Council of 17 May 2006 on machinery, and amending Directive 95/16/EC (recast) – OJ L 157, 9.6.2006
- Directive 2014/30/EU of the European Parliament and of the Council of 26 February 2014 on the harmonization of the laws of the Member States relating to electromagnetic compatibility (recast)– OJ L 96, 29.3.2014
- Directive 2011/65/EU of the European Parliament and of the Council of 8 June 2011 on the restriction of the use of certain hazardous substances in electrical and electronic equipment – OJ L 174, 1.7.2011

References to the relevant harmonized standards used or references to the other technical specifications in relation to which conformity is declared:

- EN 15194:2017
- ISO 4210:2014
- EN ISO 12100:2010

Name and address of the person authorized to compile the technical file, who must be established in the Community:

Globalnorm GmbH  
Kurfuerstenstr. 112  
10787 Berlin  
Germany  
team.compliance@globalnorm.de  
Phone: +49 30 3229027-50

For and on behalf of Yeti Cycling, LLC

**Signature:**

**Name of signatory:** Peter Zawistowski  
**Position of signatory:** Director of Engineering  
**Date of issue:** 1 November 2023  
**Location of issue:** 621 Corporate Circle, Unit B, Golden, CO 80401 USA

**UK DECLARATION OF CONFORMITY**

Manufacturer:

Yeti Cycling, LLC (d.b.a. Yeti Cycles)  
621 Corporate Circle, Unit B, Golden, CO 80401 USA

UK Authorized representative:

Silverfish UK Ltd.  
Units 3a-3c Woodacre Court, Saltash Parkway Industrial Estate,  
Burraton Road, Saltash, Cornwall,  
United Kingdom, PL12 6LY  
Matthew.Osborne@silverfish-uk.com  
Phone: 01752 843882  
<https://www.silverfish-uk.com/>

Product name(s): Yeti Cycles  
Product model(s): 160E  
Serial number range: 1AIFD010000-6LIRD619999

The object of the declaration described above is in conformity with the relevant  
Union harmonization legislation:

- Supply of Machinery (Safety) Regulations 2008
- Electromagnetic Compatibility Regulations 2016

And with the following harmonized standards:

- BS EN 15194:2017
- ISO 4210:2014

Other Applied Technical Standards

- ISO 4210-\*

Name and address of the person authorized to compile the technical file,  
who must be established in the Community:

Silverfish UK Ltd.  
Units 3a-3c Woodacre Court, Saltash Parkway Industrial Estate,  
Burraton Road, Saltash, Cornwall,  
United Kingdom, PL12 6LY  
Matthew.Osborne@silverfish-uk.com  
Phone: 01752 843882  
<https://www.silverfish-uk.com/>

For and on behalf of Yeti Cycling, LLC

**Signature:**

*Peter Zawistowski*

<b>Name of signatory:</b>	Peter Zawistowski
<b>Position of signatory:</b>	Director of Engineering
<b>Date of issue:</b>	1 November 2023
<b>Location of issue:</b>	621 Corporate Circle, Unit B, Golden, CO 80401 USA