



YETI ASR OWNER'S MANUAL

TABLE OF CONTENTS

OVERVIEW	03
FRAME FEATURES	04
ASR GEOMETRY	05
FRAME STANDARDS	06
MAINTENANCE	07
FRAME ASSEMBLY	08
BEARING PRESS ASSEMBLY	10
CABLE ROUTING SET-UP	11
DROPPER POST INSERTION GUIDE	13
EXPLODED VIEW	14
REBUILD KITS	16
FREQUENTLY ASKED QUESTIONS	18
LIFETIME WARRANTY	20
CONTACT INFORMATION	20

CONGRATULATIONS ON YOUR PURCHASE OF A NEW YETI.

We are confident your new bicycle will exceed your expectations for value, performance, and ride quality. Each frameset and component has been custom specified and designed to enhance your riding experience. Whether you are a beginner cyclist, or a seasoned pro, your Yeti bicycle will provide endless hours of two-wheeled fun.

This model specific manual is designed to be used in conjunction with the general Yeti Owner's Manual and the manuals supplied by the suspension manufacturers. If you did not receive the Yeti Owner's Manual or the manual provided by the suspension manufacturer, download the materials off the Internet, or contact your local dealer. Bicycling can be a hazardous activity even under the best of circumstances. Proper maintenance of your bicycle is your responsibility and when done properly helps reduce the risk of injury and damage to your bicycle. **The ASR is made specifically for off-road use only.**

This manual outlines basic setup and maintenance recommendations of your new Yeti. It is impossible to anticipate every situation or condition that may occur during the assembly, setup, and maintenance of your bicycle, Yeti recommends that all service and repairs be performed by your local authorized Yeti Dealer.

This manual contains many "Warnings" and "Cautions" concerning the consequences of failure to maintain or inspect your bicycle. The word "Warning" indicates a potentially hazardous situation in which, if not avoided, could result in serious injury or death. The word "Caution" indicates a potentially hazardous situation in which, if not avoided may result in minor injuries or damage to your bicycle or a component of your bicycle. Be sure to read and understand all of the Warnings and Cautions listed in the manual.



WARNING: Make sure you review and understand the warnings, instructions, and content of this manual and accompanying manuals for your bicycle.

WARNING: Technological advances have made bicycles and bicycle components more complex and the pace of innovation is increasing. It is impossible for this manual or the accompanying manuals to provide all the information required to properly repair and/or maintain your bicycle. In order to help minimize the chances of an injury, it is critical for you to have work performed by an authorized Yeti retailer.

THE LOWDOWN ON THE ASR AND ITS FEATURES.

FRAME FEATURES

1 ACTIVE SUSPENSION RACE SUSPENSION SYSTEM

The ASR delivers 115mm of rear wheel travel with our iconic ASR suspension technology. Utilizing a flex-stay pivot point and lightweight hardware throughout, the ASR provides efficient pedaling performance while still smooth and supportive when going gets rough.

2 HIGH MODULUS CARBON FIBER MAIN FRAME AND SWING ARM

High modulus carbon is hand laid to create our TURQ Series frames. That same stiffness and efficiency can also be found in our carbon series frame sets.

3 LIGHTWEIGHT SUSPENSION LINKAGE AND HARDWARE

The TURQ series ASR frame utilizes a forged 7075 aluminum rocker link to provide stiffness in a lightweight package. Additionally, titanium shock mounting hardware helps keep the weight down and hardware secure in the most demanding conditions.

4 RATTLE-FREE CABLE PORT ASSEMBLY SECURES CABLES AND HOSES TO PROVIDE A SILENT RIDE

The ASR is designed with clamping cable ports to insure a quiet ride, reduced cable movement and clean aesthetic. The ports are configurable so you can choose cable or wireless components without leaving behind open housing ports.

5 INTEGRATED 41MM / 52MM TAPERED HEAD TUBE

Using an integrated head tube design on the ASR allows for a larger head tube with more area, which results in increased stiffness, and lower overall ride height without compromising any performance.

6 TWO WATER BOTTLE MOUNTS

The ASR is able to fit two water bottles inside the main frame to keep you hydrated on those extra big days.

7 CUSTOM DOWN TUBE PROTECTOR AND RIBBED CHAIN GUARDS TO DECREASE CHAIN SLAP NOISE

Custom seatstay, chainstay, muck fender, and down tube guards keep the ride quiet while protecting the frame.

8 INTEGRATED AXLE AND UNIVERSAL DERAILLEUR HANGER SYSTEM

Dedicated 12 x 148 boost dropouts with SRAM's universal derailleur hanger (UDH) provide strength, stiffness and easy hanger and wheel installation.

9 CUSTOM TUNED REAR SHOCK

We develop custom suspension tunes from the ground up here in Golden, CO to optimize suspension performance to perfectly compliment the ASR suspension kinematics. For help setting up your suspension, please visit our Shock Setup Guide.

<https://shocksetup.yeticycles.com/bikes>

10 CUSTOM INTEGRATED CHAINGUIDE

The ASR is equipped with an ultra lightweight custom integrated chainguide for worry free chain retention in the roughest of terrain.

11 CABLE ROUTING FOR INTERNALLY ROUTED LONG DROP SEAT POST

This may be an "XC" bike, but it has the soul of an enduro machine. We know you'll be riding it with a dropper post.

GEOMETRY ASR

120MM FORK	XS	SM	MD	LG	XL
A SEAT TUBE LENGTH	400	410	430	470	495
B EFF. TOP TUBE LENGTH	554	574	600	623	653
C HEAD TUBE ANGLE°	66.5	66.5	66.5	66.5	66.5
D EFF. SEAT TUBE ANGLE°	75.5	75.5	75.5	75.5	75.5
E ACTUAL SEAT TUBE ANGLE°	70.4	70.8	71.2	71.6	72.1
F CHAINSTAY LENGTH	433	435	437	439	441
G WHEELBASE	1122	1144	1174	1201	1236
H ESTIMATED BB HEIGHT	335	335	335	335	335
I STANDOVER	768	768	771	771	776
J HEADTUBE LENGTH	92	92	101	111	133
K FORK (AXLE TO CROWN)	531	531	531	531	531
L FORK (OFFSET)	44	44	44	44	44
M STACK	592	592	600	610	630
N REACH	400	420	445	465	490
O FRONT CENTER	689	709	737	762	795
P VERTICAL FORK TRAVEL	110	110	110	110	110

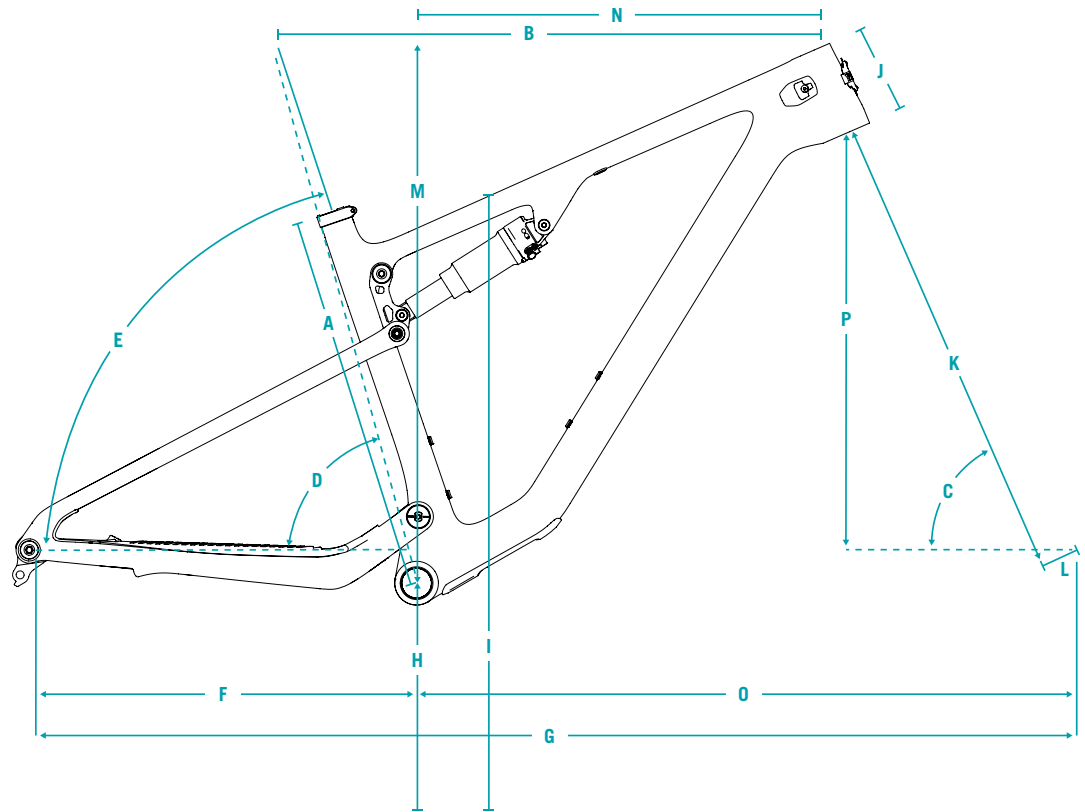

FIT

X-SMALL	4'10" - 5'3"
SMALL	5'1" - 5'7"
MEDIUM	5'5" - 5'11"
LARGE	5'10" - 6'3"
X-LARGE	6'1" - 6'7"

FRAME STANDARDS



TRAVEL	115MM
WHEEL SIZE	29"
FRAME SIZE	XS, SM, MD, LG, XL
REAR SHOCK	190MM X 40MM
BOTTOM BRACKET	BSA 73MM
REAR WHEEL	148MM X 12MM (BOOST)
SEATPOST	31.6MM
CHAINLINE	55MM
HEADSET	INTEGRATED 41MM/52MM TAPERED
REAR BRAKE POST MOUNT	160MM
SHOCK HARDWARE	FRONT: M8X20MM REAR: M8X30MM
MIN/MAX CHAINRING	28T MIN/36T MAX (XS-S) ; 28T MIN/38T MAX (M-XL)
MIN MAX REAR ROTOR	160MM MIN/180MM MAX
AXLE SPEC	172MM M12X1.0

KEEP YOUR YETI FRESH AND CLEAN

MAINTENANCE OVERVIEW

Following these guidelines will help maintain the performance of your bicycle and prevent more serious problems from arising. It is important to remember that service intervals can vary depending on climate, trail conditions and riding frequency. Servicing your bike requires special knowledge and tools. If you are unsure about working on your own bicycle, contact your authorized Yeti Dealer for more information on general bicycle maintenance.

SCHEDULE	BEFORE EACH RIDE	MONTHLY	3 MONTHS	ANNUALLY
Clean and lube chain	●			
Check tire pressure	●			
Clean bike of mud and debris	●			
Check brake function	●			
Ensure all cable ends are covered with crimped cable end caps	●			
Check rims for deformations or cracks	●			
Check for loose bolts and tighten, if necessary		●		
Check headset and tighten/loosen, if necessary		●		
Check / replace brake pads			●	
Check tires for wear			●	
Check spoke tension, retention, if necessary			●	
Check chain for wear, replace if necessary			●	
Complete tune-up performed by an authorized Yeti Dealer				●

TORQUE

Yeti strongly recommends using a torque wrench when assembling your frame. Torque specifications for individual parts on the ASR are listed below, as well as in the step by step assembly instructions later in the manual. For general bicycle maintenance please consult the torque specifications of the component you are adjusting.

KEY TORQUE SPECS

PART #	DESCRIPTION	TORQUE (Nm)
300040550	SCREW, MALE, M8X1, 13L, MAIN PIVOT, AL	15
300040553	SCREW, MALE, M8X1, 16.25L	12
300040554	SCREW, M10 X 1.0, 20.75L, SS PIVOT	15
300040558	BHCS, CUSTOM, M6 X 1.0, 12L, TI	10
300060080	SRAM UNIVERSAL HANGER	25
100425035	AXLE, M12X1 X 172L, BOLT-ON, BLACK	10
300030177	SCREW, FH, M4 X 0.7, 25L	2.5
300030357	SHCS, LOW PROFILE, M5 X 0.8, 16L	5
300030170	SHCS, LOW PROFILE, M5 X 0.8, 10L	5
300040560	SHCS, M4 X 0.7 - 6L, ULTRA LOW PROFILE	2

FRAME ASSEMBLY

YETI TIPS

Make sure your tools are in good condition. A worn allen key can round the hex on a bolt not allowing for proper torque.

Torque settings are listed throughout the instructions and on page 7 of this manual. It is important to prep all bolt threads. The instructions denote whether to use a Loctite compound or grease and part locations, listed in parentheses, are shown in the exploded view on page 13. Please ensure all prep call outs are followed.

WARNING: Failure to follow prep instructions could lead to serious frame issues.

WARNING: Service on Yeti bicycles requires special knowledge and tools. Yeti Cycles recommends that all service and repairs be performed by an authorized Yeti Dealer.

TOOLS NEEDED

- Torque wrench(es) 5-25Nm
- T-25 torx bit
- 2.5mm allen key
- 3mm allen key
- 5mm allen key
- 6mm allen key
- 8mm allen key
- Blue Loctite (243)
- Grease
- Internal cable routing kit

OPTIONAL BUT HELPFUL

- 10mm guide pins
- 8mm guide pins

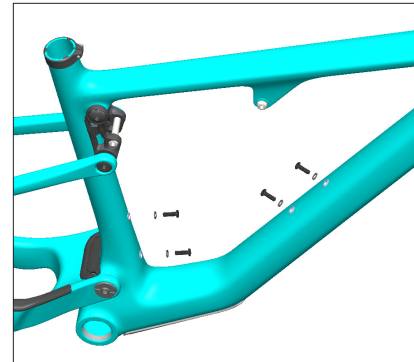

01

Grease threads and install 2x Low Profile H20 Bolts (3.23) and Washers (3.24) to front triangle.

Torque: **5 Nm** (or hand tight)

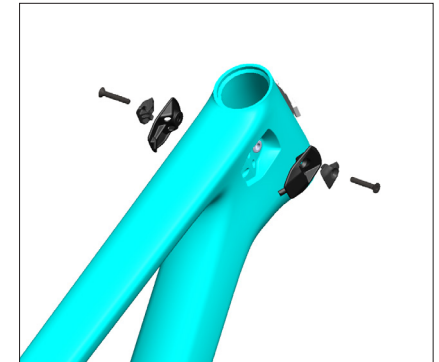

02

Place a Head Tube Cable Port Cover (3.17) into each recess behind the head tube.

Place a Double Port Clamp (3.18) into both covers. Secure with M4 x 25L FHCS (3.19).

Tighten until snug. Hardware can be torqued to **2-3 Nm** after housing installation.



03

Install Lower Access Door (3.25) to the Front Triangle using Low Profile M5 Screws (3.23), apply Blue 243 Loctite.

Torque: **5 Nm**

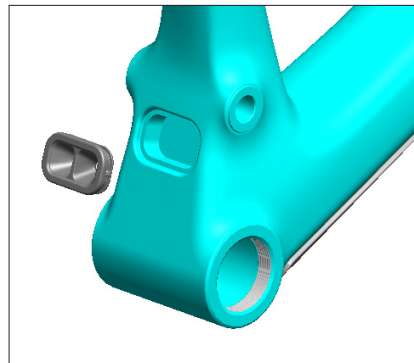

04

Press Routing Grommet (3.20) in the back side of Front Triangle.

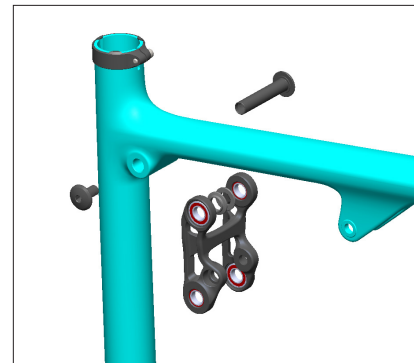

05

Place 2x Race Extenders (3.9) onto the upper bearings in Link Assembly (3.1). The side of the race extender that has the raised smaller diameter should fit against the bearing, allowing the flat side to rest against the carbon. Lightly grease under the flange of the race extenders will help hold them in place during install. Install into Front Triangle using a 10mm guide pin if available.

Lightly grease shaft of the Link Pivot Collet Axle (3.7) and install. Apply Blue 243 Loctite to the threads on the Link Pivot Screw (3.5) and secure Link Pivot Axle.

Torque: **12 Nm**

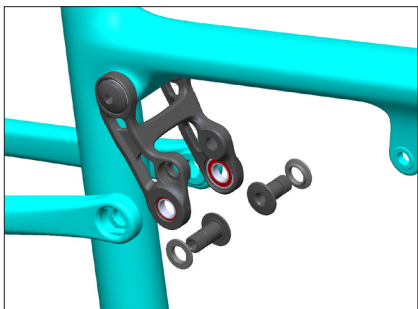
**06**

Place 2x Race Extenders (3.9) onto the lower bearings in Link Assembly (3.1). The side of the race extender that has the raised smaller diameter should fit against the bearing, allowing the flat side to rest against the carbon. Lightly greasing under the flange of the race extenders will help hold them in place during install.

Rotate Rear Triangle and Link together, lining up SS Pivot bores and slightly flexing the seatstay if needed. The link will have to be rotated forward in order for the SS pivot screws to clear the seat tube.

USE CAUTION to not scratch the seat tube.

Lightly grease shaft and apply Blue 243 Loctite to threads of Seat Stay Pivot Screws (3.6). Grease seatstay frame cavities where Keyed Nut (3.8) will be installed.

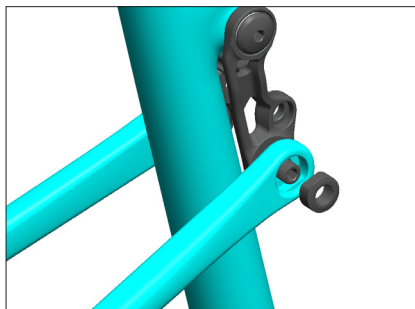
**07**

Install 2x Seat Stay Pivot Screws (3.6) from the inside of the Link and partially into the Rear Triangle. Place 2x plain Keyed Nut (3.8) into the Rear Triangle.

While supporting the rear triangle so the link does not contact the seat tube, use a wrench from the outside of the Swingarm to begin tightening in the "left-hand" direction (this is still a standard thread, but installed from the inside), tightening the SS Pivot Screw and Keyed Nut.

Torque: 15 Nm

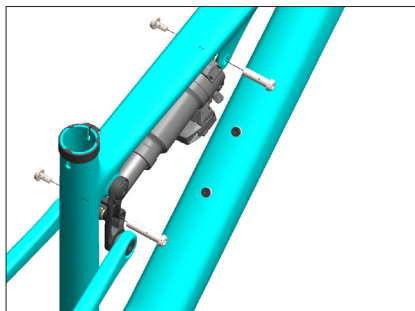
**09**

Install the Shock into the frame by securing eyelets with a Guide Pin. Lightly grease shaft of female 8x38mm bolt (3.12) and install with washer (3.13) through the link and shock. Apply Blue 243 Loctite to threads of the M6 Male Bolt (3.10) with washer (3.14) and secure.

Lightly Grease shaft of female 8x29mm bolt (3.11) with washer (3.13) and install through shock tabs on the Front Triangle and shock eyelet. Apply Blue 243 Loctite to threads of the M6 Male bolt (3.10) with washer (3.14) and secure.

Torque: 10 Nm

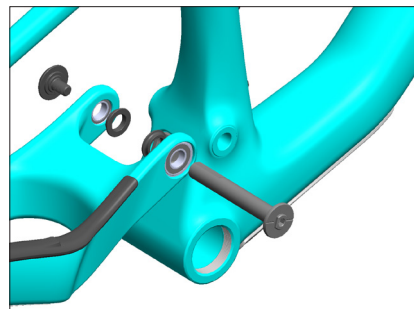
**08**

Place 2x Race Extender (3.4) onto rear triangle main pivot bearings. The side of the race extender that has the raised smaller diameter should fit against the bearing, allowing the flat side to rest against the carbon. Lightly greasing under the flange of the race extenders will help hold them in place during install.

Slide rear triangle assembly onto main pivot. Lightly grease shaft of the Keyed Main Pivot axle (3.2), apply Blue 243 Loctite to the threads of the Main Pivot Screw (3.3) and secure.

Torque: 15 Nm

WARNING : Ensure the Flats on the Keyed Axle (3.2) are aligned with the Flats in the Front Triangle. DO NOT force installation. A 5mm allen key can help rotate the axle in the frame if needed to align the axle, but do not use this hex to tighten or loosen this bolt.

QC CHECK

Cycle rear triangle through to make sure motion is smooth.

Take precaution to make sure link does not contact seat tube.

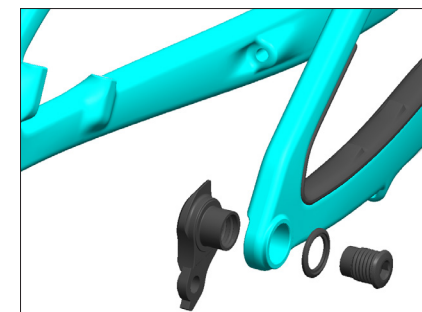
**10**

Install Universal Hanger (3.15) to the frame. Do not use grease. Note that the hanger cap bolt is REVERSE THREADED.

Torque: 25 Nm

BEARING PRESS ASSEMBLY

LINK BEARING PRESS

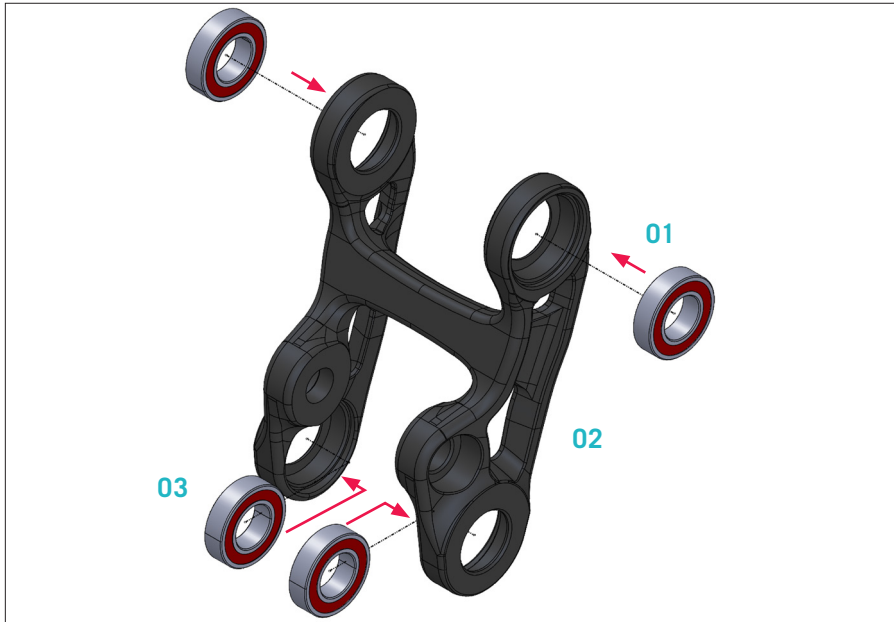

- 01** Clean all four outer bearing races with isopropyl alcohol and apply bearing retaining compound. (Green 609 Loctite)
- 02** Press both upper bearings into the link using a 10x19mm arbor. Support space between the tabs on the link while pressing bearings to ensure the link does not bend or get damaged.
- 03** Press both lower bearings into the link using a 10x19mm arbor.

MAIN PIVOT BEARING PRESS

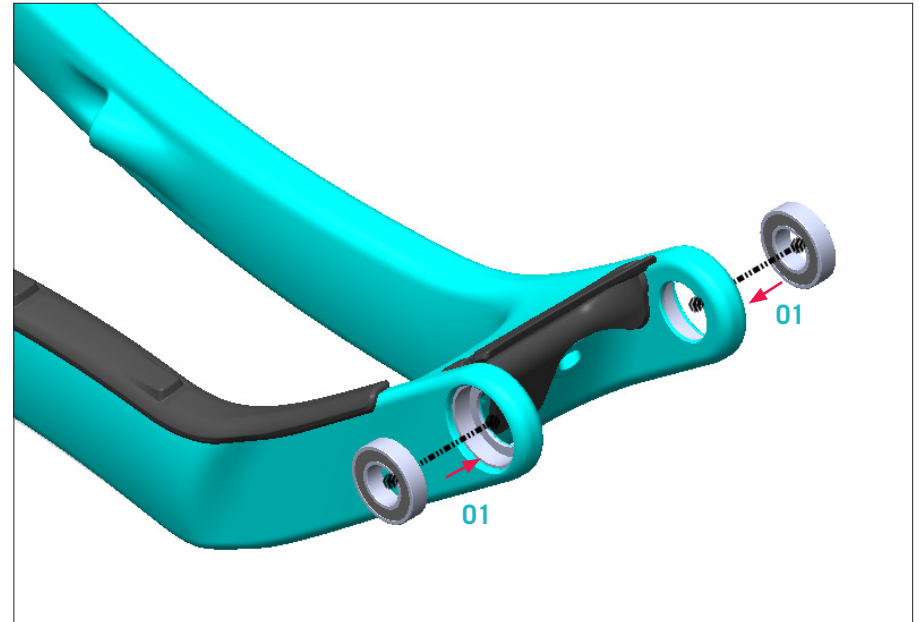

- 01** Clean both outer bearing races with isopropyl alcohol and apply bearing retaining compound. (Green 609 Loctite)
- 02** Press one bearing at a time using a 12x24mm arbor
NOTE : Use caution when contacting the inside carbon face to avoid any damage to the paint. It is not advisable to press both bearings in at the same time.

CABLE ROUTING SET-UP

NON DRIVE CABLE ROUTING

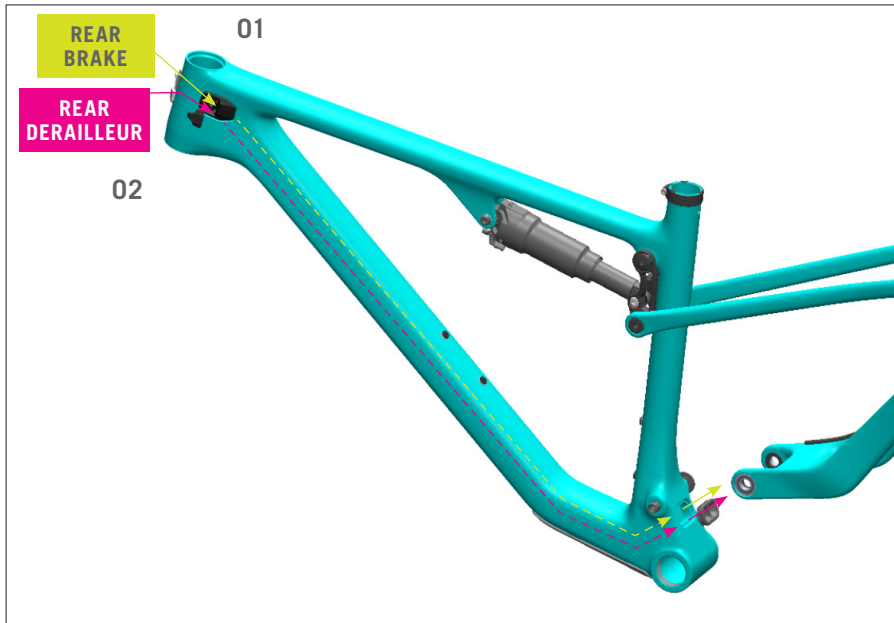

DRIVE SIDE CABLE ROUTING

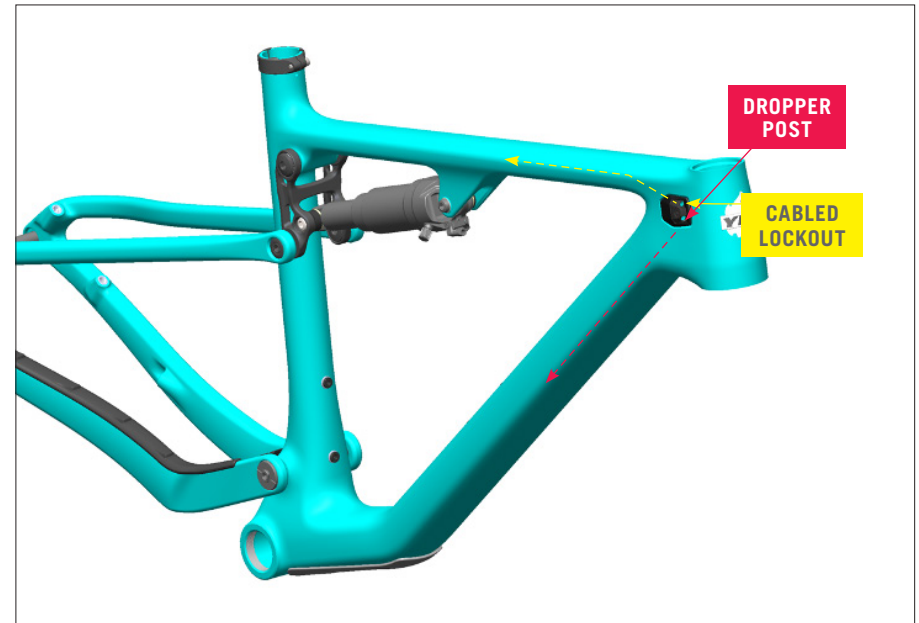

FRONT TRIANGLE - REAR TRIANGLE VIEW FROM BOTTOM



- 01 Route brake cable first through the nondrive side port in the rear tri, cable routing grommet, and the top port in the headtube.
- 02 If applicable route the rear derailleur cable through the drive side rear triangle port, cable routing grommet, and the bottom port in the headtube.

Cable routing is most easily done with the seat stay pivots assembled and the main pivot free to allow the rear tri to swing away from the front triangle.

CABLE ROUTING SET-UP

DROPPER POST ROUTING SET-UP

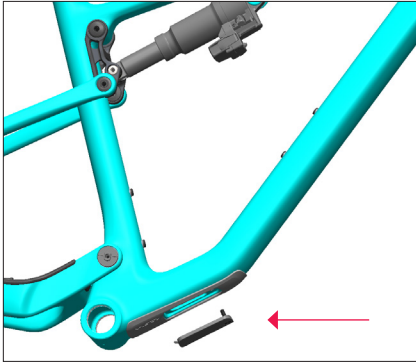

01

With a 3mm allen wrench, remove the lower access door.



02

Install your seatpost housing into the drive-side head tube port, pushing until it exits near the downtube cable port access hole.

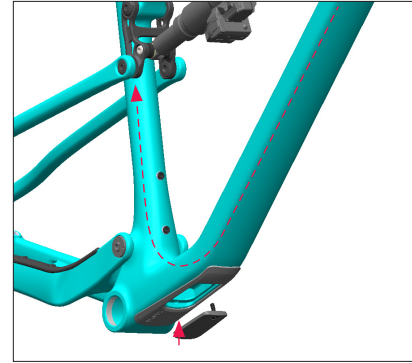

03

The hole under the downtube protector provides an access point to use your finger to help push the housing around the bend in the frame up into the seat tube.

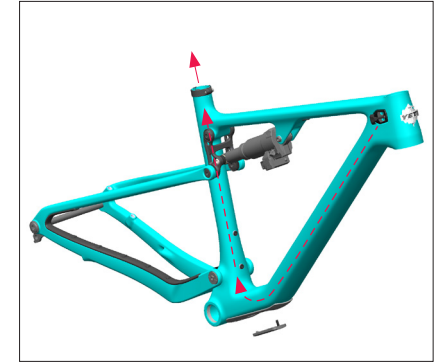

04

While pushing the housing into the head tube port, continue guiding the cable up the seat tube through the access hole until the housing exits the seat tube.

CABLE LOCKOUT ROUTING SET-UP

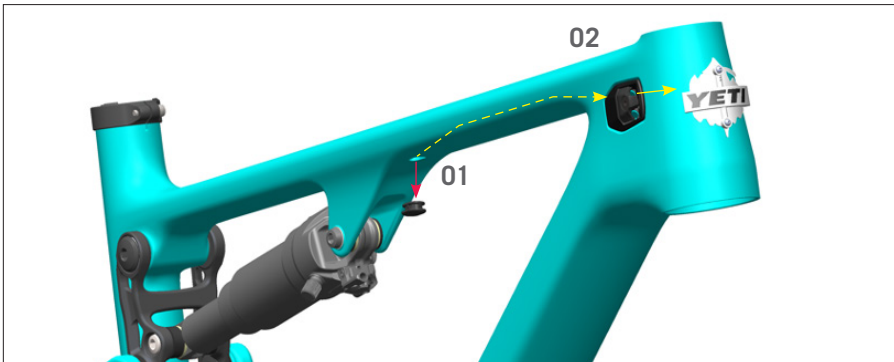

01

Remove rubber port grommet from frame.

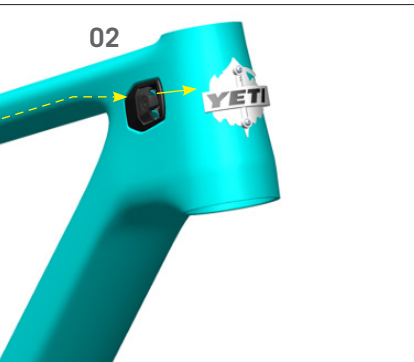

02

Route cable housing through the frame and out of the top port in the headtube on drive side.

DROPPER POST INSERTION GUIDE

Droppers are an essential tool for the modern mountain bike but proper clearance checks are required before heading out for your first ride.

The key checks are as follows:

Ensure your dropper is short enough to fit into the seat tube without interfering with the frames structure but you are still able to achieve your desired BB-Saddle measurement. See the max insertion depth chart to confirm this distance for wired and wireless posts.

There are some scenarios where you can fit a longer dropper in your frame but when you drop your dropper the saddle or battery for AXS posts could interfere with your tire during a suspension compression. See the Min BB-Saddle at full drop to confirm this distance.

Always perform a final check to ensure your post is installed to at least the minimum insertion line. Also, compress the dropper and suspension, let the air out of your shock, to ensure there is no tire interference to the saddle or AXS battery at full bottom out.

We strive to spec out dropper lengths to provide the maximum drop for the highest percentage of our riders. There is a wide range of saddle heights for every frame size. There is a possibility saddle height could fall outside of this range. A small percentage of customers might find they require a shorter or longer post given their saddle height.

Please ensure you check the minimum dimensions in the below tables before going for your first ride. Failure to do so could result in tire to saddle rub or tire to battery contact for AXS posts.

Please confirm both of these measurements, they are both required to ensure proper dropper fitment.

If you have any questions, please contact Yeti or your local bike shop.

MINIMUM BB TO SADDLE CABLED DROPPER (MM)*		
FRAME SIZE	X-SMALL	494**
	SMALL	493**
	MEDIUM	499**
	LARGE	539**
	X-LARGE	564**

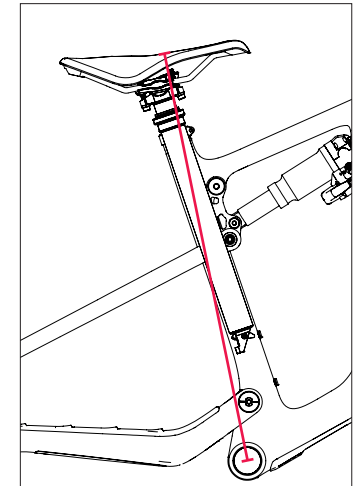

*These measurements are only for cabled droppers. Please make sure if you have a wireless post you confirm that there is not any interference of the tire hitting the battery when the post is fully dropped and the suspension is fully compressed.

**If you go lower than the listed minimum, you run the risk of tire to saddle interference.

MAX INSERTION WIRELESS DROPPER (MM)*		
FRAME SIZE	X-SMALL	278
	SMALL	287.5
	MEDIUM	308
	LARGE	348
	X-LARGE	373

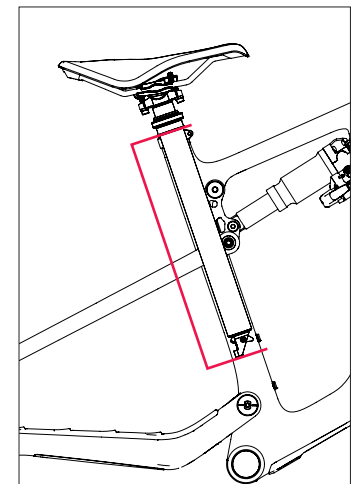

*Subtract 34mm for a cabled dropper to accommodate housing bend angle.

EXPLODED VIEW

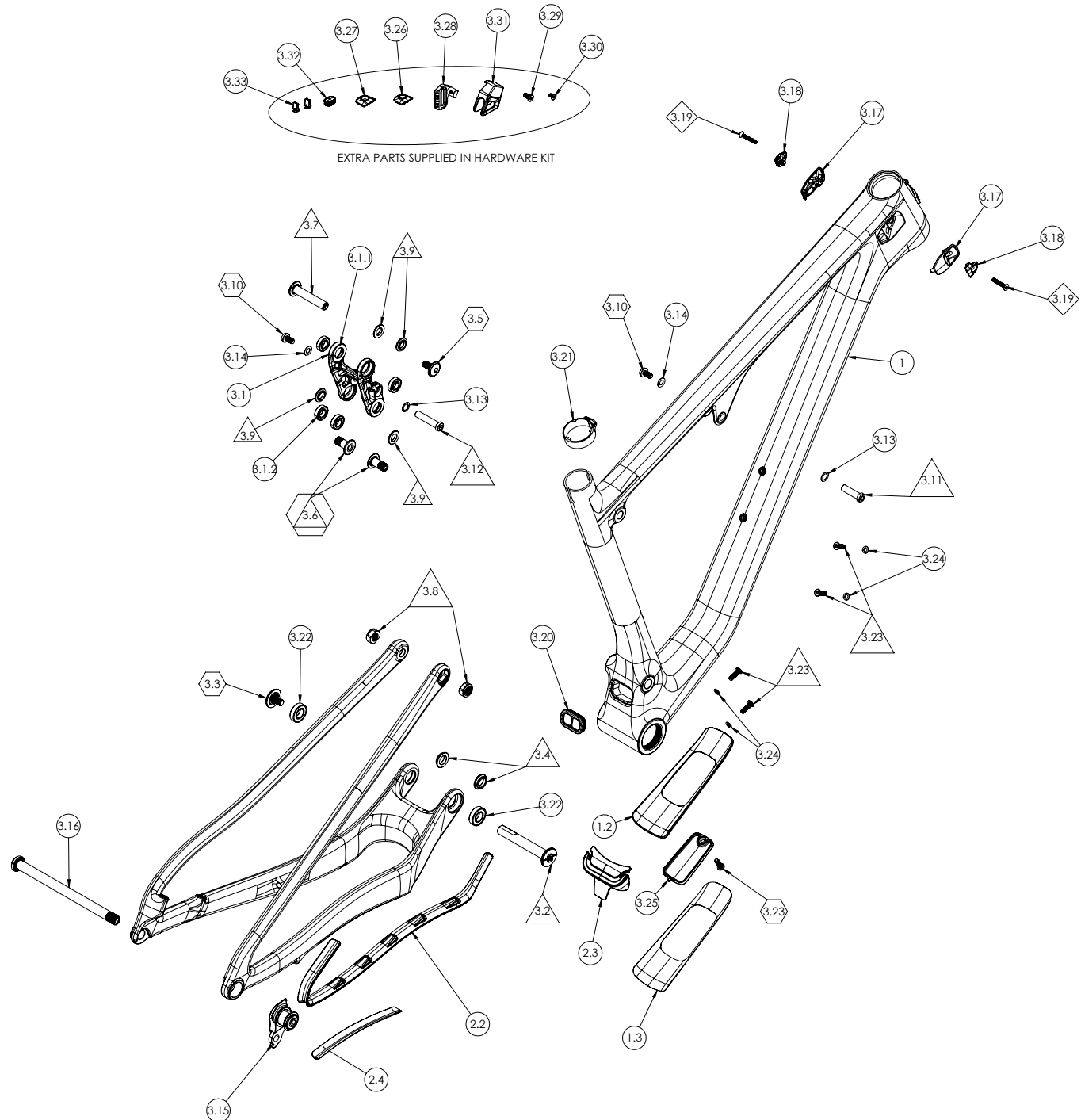

EXTRA PARTS SUPPLIED IN HARDWARE KIT

PREP KEY

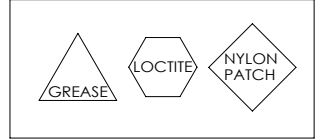

EXPLODED VIEW PARTS LIST

ITEM #	PART #	DESCRIPTION	TORQUE (NM)	QTY
1		ASR FRONT TRIANGLE ASSEMBLY		1
1.2	300040561	GUARD, DT, ASR		1
1.3	300040569	PROTECTOR, DT, CLEAR, ASR		1
2		ASR REAR TRIANGLE ASSEMBLY		1
2.2	300040566	CHAINSTAY GUARD, UPPER, ASR		1
2.3	300040564	GUARD, RT MAIN PIVOT, ASR 2024		1
2.4	300040570	PROTECTOR, CHAINSTAY, CLEAR, ASR		1
3		ASSY, ASR HARDWARE, T SERIES		1
3.1.1	200020470	ASSY, ASR LINK, T/ULT-SERIES 7075,		1
	300040547	ASSY, ASR LINK, C-SERIES 6061		1
3.1.2	300020063	BEARING, 6800, 19 X 10 X 5MM		4
3.2	300040548	AXLE, KEYED, 12MM X 80L, M8 THREAD, GUIDE MOUNT HEAD		1
3.3	300040550	SCREW, MALE, M8X1, 13L, MAIN PIVOT, AL	15	1
3.4	300040549	SPACER, 20.5 X 12 X 4.25L		2
3.5	300040553	SCREW, MALE, M8X1, 16.25L	12	1
3.6	300040554	SCREW, M10 X 1.0, 20.75L, SS PIVOT	15	2
3.7	300040552	AXLE, FEMALE, 10MM X 52.25L, M8 THREAD		1
3.8	300040555	KEYED NUT, M10, 17.5 OD, 7.5L		2
3.9	300040551	SPACER, 18 x 10 x 3.25L		4
3.10	300040558	BHCS, CUSTOM, M6 X 1.0, 12L, TI	10	2
3.11	300040556	SCREW, FEMALE, M6 X 1.0, 29.0L, 8MM OD, TI		1
3.12	300040557	SCREW, FEMALE, M6 X 1.0, 38.0L, 8MM OD, TI		1
3.13	300030069	WASHER 8.5 X 12.5 X 0.5 MM		2
3.14	300030062	WASHER 6.5 X 12.5 X 0.5 MM		2
3.15	300060080	SRAM UNIVERSAL HANGER	25	1
3.16	100425035	AXLE, M12X1 X 172L, BOLT-ON, BLACK	10	1
3.17	300040524	CABLE PORT COVER, HEAD TUBE, 2 PIECE		2
3.18	300040522	CLAMP, HT PORT DOUBLE, PA6		2

3.19	300030177	SCREW, FH, M4 X 0.7, 25L	2.5	2
3.20	300040563	ROUTING GROMMET, DUAL PORT, ASR		1
3.21	300060083	YETI SEAT COLLAR BOLT ON 36.4, T-SERIES BIKE YOKE SQUEEZY, 36.4		1
3.22	300020056	BEARING, 6901-2RS, 12x24x6		2
3.23	300030357	SHCS, LOW PROFILE, M5 X 0.8, 16L	5	5
3.24	300030358	WASHER 5.2 X 8.8 X 1.0 MM, STAINLESS		4
3.25	300040562	ACCESS COVER, DOWN TUBE, ASR		1
3.26	300040521	CLAMP, HT PORT SINGLE, PA6		1
3.27	300040523	COVER, HT PORT, BLIND, PA6		1
3.28	300040559	MOUNT PLATE, CHAIN GUIDE, ASR		1
3.29	300030170	SHCS, LOW PROFILE, M5 X 0.8, 10L	5	1
3.30	300040560	SHCS, M4 X 0.7 - 6L, ULTRA LOW	2	1
3.31	300040567	CHAIN GUIDE, ASR		1
3.32	300040565	PLUG, ASR LOCKOUT ROUTING, TPR,		1
3.33	300040510	FRAME PLUG, CABLE PORT		2

REBUILD KITS

PART #	DESCRIPTION	QTY
200020475	ASR BEARING REBUILD KIT 2024- CURRENT	
300020063	BEARING, 6800 LLU MAX, 10 X 19 X 5	4
300020056	BEARING, 6901-2RS, 12 X 24 X 6	2
200020476	ASR CABLE PORT KIT 2024-CURRENT	
300040524	CABLE PORT COVER, HEAD TUBE, 2 PIECE	2
300040522	CLAMP, HT PORT DOUBLE, PA6	2
300030177	SCREW, FH, M4 X 0.7, 25L	2
300040563	ROUTING GROMMET, DUAL PORT, ASR	1
300040521	CLAMP, HT PORT SINGLE, PA6	2
300040523	COVER, HT PORT, BLIND, PA6	1
300040565	PLUG, ASR LOCKOUT ROUTING, TPR, 12X7	1
300040510	FRAME PLUG, CABLE PORT	2
200020477	ASR DOWNTUBE PORT COVER KIT 2024-CURRENT	
300030357	SHCS, LOW PROFILE, M5 X 0.8, 16L	1
300040562	ACCESS COVER, DOWN TUBE, ASR	1
200020478	ASR PROTECTOR KIT 2024-CURRENT	
300040569	PROTECTOR, DT, CLEAR, ASR	1
300040570	PROTECTOR, CS LOWER, CLEAR, ASR	1
300040561	DOWNTUBE GUARD, MY24 ASR	1
300040564	REAR TRIANGLE MAIN PIVOT GUARD, ASR	1
300040566	CHAINSTAY GUARD UPPER, ASR	1
200020480	ASR CHAINGUIDE REBUILD KIT 2024-CURRENT	
300040559	MOUNT PLATE, CHAIN GUIDE, ASR	1
300030170	SHCS, LOW PROFILE, M5 X 0.8, 10L	1
300040560	SHCS, M4 X 0.7 - 6L, ULTRA LOW PROFILE	1
300040567	CHAIN GUIDE, ASR	1

200020421	SHOCK EXTENDER KIT	
300040543	SHOCK EXTENDER, ASR, 25MM	1
300020032	BEARING, 398 MAX DBL, 8 X 19 X 10/11	2
200020479	ASR HARDWARE REBUILD KIT 2024-CURRENT	
300040548	AXLE, KEYED, 12MM X 80L, M8 THREAD, GUIDE MOUNT HEAD	1
300040550	SCREW, MALE, M8X1, 13L, MAIN PIVOT, AL	1
300040549	SPACER, 20.5 X 12 X 4.25L	2
300040553	SCREW, MALE, M8X1, 16.25L	1
300040554	SCREW, M10 X 1.0, 20.75L, SS PIVOT	2
300040552	AXLE, FEMALE, 10MM X 52.25L, M8 THREAD	1
300040555	KEYED NUT, M10, 17.5 OD, 7.5L	2
300040551	SPACER, 18 x 10 x 3.25L	4
300040558	BHCS, CUSTOM, M6 X 1.0, 12L, TI	2
300040556	SCREW, FEMALE, M6 X 1.0, 29.0L, 8MM OD, TI	1
300040557	SCREW, FEMALE, M6 X 1.0, 38.0L, 8MM OD, TI	1
300030069	WASHER 8.5 X 12.5 X 0.5 MM	2
300030062	WASHER 6.5 X 12.5 X 0.5 MM	2
300030357	SHCS, LOW PROFILE, M5 X 0.8, 16L	5
300030358	WASHER 5.2 X 8.8 X 1.0 MM, STAINLESS ED BLACK	4
300040562	ACCESS COVER, DOWN TUBE, ASR	1

200020470	ASR 7075 ALLOY LINK W/ BEARINGS 2024-CURRENT	
200020469	ASR 6061 ALLOY LINK W/ BEARINGS 2024-CURRENT	
200020481	ASR FRAME PROTECTOR KIT SHEET GLOSS 2024-CURRENT	
200020484	ASR FRAME PROTECTOR KIT SHEET ULTIMATE 2024-CURRENT	

FREQUENTLY ASKED QUESTIONS (1 OF 2)

WHAT IS THE DIFFERENCE BETWEEN THE TURQ AND CARBON SERIES ASR?

TURQ Series bikes are manufactured with the highest quality and best-performing carbon fiber available and offer the perfect balance of stiffness, durability, and compliance. The result is a bike that feels smooth, solid and aggressive. Carbon series bikes use a modified carbon fiber layup of our TURQ Series bikes. By using different materials and tweaking the fiber layup, we are able to make a more aggressively priced carbon high-performance mountain bike while maintaining the strength and stiffness of its higher end sibling. The carbon series ASR weighs a bit more, about 160g for a frame.

CAN I REPLACE OR MODIFY ANY YETI FRAME PARTS ON MY ASR?

All replacement frame parts for your ASR can be found through your local dealer or on our webstore. Only genuine Yeti parts should be used when replacing any parts on your frame. We know there are a lot of aftermarket products out there that seem legit but we do not have the ability to qualify and ensure all of these products are safe to use on our frames. If it is found that any frame part has been modified or replaced all warranties will be voided and all liability will be assumed by the customer.

CAN I CHANGE OR UPGRADE THE SPEC COMPONENTS ON MY ASR?

There are many options in aftermarket parts to upgrade or personalize your bike. Some parts are standardized, especially from the big brands like Fox, Shimano, SRAM etc. You should always confirm with a professional mechanic that your parts are the correct standard and correctly and securely mount to your bike without any interference or play. Pay special attention to all the bike's standards and check the fit before use.

CAN I USE AN ANGLESET ON THE ASR?

The ASR was designed with an integrated headset which has the headset cups molded into the frame so you can easily drop the bearings into the cups. There are some aftermarket angle-sets available for this style headset however the frame was not tested for the use of these and therefore should not be used. Yeti's warranty will be voided if it is found an angleset was installed on the frame and all liability will be assumed by the customer. See "What travel fork is the ASR designed to use" for more information.

WHAT TRAVEL FORK IS THE ASR DESIGNED TO USE?

The ASR is designed to run a 120mm travel fork. We tested this frame to 20mm over the spec fork. So if you're feeling the need to beef up the fork you can run up to a 140mm fork no problem. Bottom line - max axle to crown measurement of 555mm. Increasing your fork travel will slacken the head angle and seat tube angle and raise the bottom bracket. Running a shorter fork is fine too if that suits you. Shortening the fork will steepen the head angle and seat tube angle and lower the bottom bracket. For more geometry information, check out the geometry section.

HOW BIG OF A TIRE CAN I FIT ON THE ASR?

The short answer is the ASR can accept up to a 2.4" tire. There is great tire clearance on the ASR but tire sizes vary widely by manufacturers, so it is hard to give a number that works for all brands.

CAN I FIT A WATER BOTTLE INSIDE THE FRONT TRIANGLE?

Yes, all frames have mounts for water bottles on the seat tube and down tube. We designed the ASR to accommodate at least one standard sized water bottle inside each front triangle. Our recommended max bottle capacity per size are outlined below, but exact fitment may depend on your specific shock, cages, and bottles of choice.

XS: 21oz on seat tube, 15oz on down tube

S-XL: 21oz on seat tube, 24oz on down tube

We recommend using Yeti's 15oz Hot Lap bottle for any tight-clearance fitment and a side-entry cage for easiest access.

WHAT CRANKS AND BOTTOM BRACKET CAN I USE ON THE ASR?

The ASR bottom-bracket standard is BSA 73mm and only wide "q" factor cranks are compatible. It is readily compatible with Shimano, SRAM, and RaceFace cranks, but a fit check is required for other brands.

WHAT REAR WHEEL AXLE FITS ON MY ASR?

The ASR is designed to work exclusively with SRAM's Universal Derailleur Hanger at 12x148mm spacing. This axle has a thread pitch 12x1.0 and a length of 172mm. Note that this axle is only compatible with frames specifically designed with the Universal Derailleur Hanger.

WHAT TYPE OF HEADSET DOES THE ASR USE?

The ASR uses an Integrated 41mm/52mm tapered headset. This system allows for the headset bearings to be contained inside the head tube for an overall lower ride height, more simplified installation, and increased stiffness.

HOW BIG OF A ROTOR WILL FIT ON THE FRAME?

The ASR has a direct mount rear brake tab and can run a 160mm rotor without the need for a brake adaptor. With the use of a brake adaptor the frame can accept up to a 180mm rotor.

CAN I RUN A STEALTH SEATPOST DROPPER ON THE ASR?

Yes. The ASR has routing options for stealth only.

FREQUENTLY ASKED QUESTIONS (2 OF 2)

WHAT CHAINLINE WAS THE ASR DESIGNED AROUND?

The ASR was designed around a 55mm Boost chainline. Depending on the crank and chain ring configuration you can run other chainlines but you will have to do a clearance check first. Minimum clearance from the chainring teeth to the chainstay is 3.5mm.

WHAT IS THE MAX SIZE SINGLE-CHAINRING THAT FITS ON THE ASR?

Without getting too technical, the max chainring size depends on the crank chainline and the chainring shape. Minimum clearance from the chainring teeth to the chainstay is 3.5mm.

- Shimano / SRAM 55mm chainline Boost cranks: 36t (XS-S)/38t (M-XL)
- Minimum Chainring Size: 28t (All sizes)

Confused? Ask your local dealer or call us 303.278.6909.

DOES THE ASR HAVE ISCG MOUNTS?

No. The ASR comes with an optional integrated chain guide device if you want to increase chain security.

WHAT TYPE OF SHOCK DOES THE ASR USE?

The ASR uses a 190 x 40mm shock. The shock can be configured with or without remote lockout capability. 40mm is the max designed shock stroke, and longer strokes are prohibited.

WHAT TYPE OF SHOCK HARDWARE DOES THE ASR USE?

The ASR uses M8x20mm front hardware and M8x30MM rear hardware (standard eyelet hardware or bearing-mount).

CAN I PUT A COIL SHOCK ON MY ASR?

No, the ASR will not fit a coil shock due to sizing constrictions and limited frame clearance in the bike's link.

WHAT PERCENTAGE SAG DO YOU RECOMMEND FOR THE ASR?

We would advise starting with 30% sag, or 12mm of shock stroke for optimal pedaling efficiency and terrain compliance. Be sure to set your sag at your normal riding weight, gear included. Feel free to venture slightly above or below 30% to suit your personal preference.

Visit our shock set up page to help set up your suspension, <https://shocksetup.yeticycles.com/calculator>

WHAT SIZE SEAT POST DOES THE ASR USE?

The ASR uses a 31.6mm seat post.

WHAT SIZE SEAT COLLAR DOES THE ASR USE?

The ASR uses a 36.4mm seat collar. T-Series frames utilize the Bike Yoke Squeezy clamp and the paint masking on the seat tube is specific for this seat collar. Alternate seat collars could damage paint.

WHAT IS THE WARRANTY ON MY ASR?

The ASR has a LIFETIME manufacturer's warranty.

WHAT IS THE LONGEST TRAVEL DROPPER POST I CAN RUN ON THE ASR?

This is mostly defined by your inseam. There is no frame limitation, so in theory, you can run any travel as long as you are above the minimum insert mark and you are not so low your tire rubs on your saddle. Your local Yeti dealer can help you sort this out. We run 125mm drop on XS-SM frames, 150mm on MD-XL with the Fox Transfer SL Dropper Post. Other dropper post models can go up to 240mm but always check the fit guide in the owner's manual to ensure alternative dropper models will fit correctly.

HOW DO I SETUP MY ROCKSHOX FLIGHT ATTENDANT SUSPENSION?

Please visit [SRAM.com](https://www.sram.com) or download the SRAM AXS mobile app for information on tuning your Flight Attendant equipped bike.

SRAM also has video tutorials, see the link below.

<https://www.youtube.com/playlist?list=PLIVKlyOSFFsl8XovLz0w50hXApYH2GLEj>

CAN I TAKE OFF THE SUSPENSION REMOTE LOCKOUTS ON MY TURQ-SERIES SPEC?

Technically, you can remove the remote lockouts from your fork and shock but you will no longer be able to switch between the 3 positions, Open/Pedal/Lock, and it will default to the Open position. If you prefer the 3 position controls to be on the fork and shock then you need to replace the entire fork or shock with the lever adjust versions.

WHAT IS THE MAX SYSTEM WEIGHT FOR THE ASR?

The max system weight is the the total allowed weight of the bike, meaning rider + gear + bike weight. This is driven off of the ratings of componentry. Be sure to check the specific components on your unique build. Our spec builds are driven by the max system weight of the wheels: M1900 and XM1700 are rated to 120kg; XRC1200 are rated to 110kg.

LIFETIME WARRANTY

HERE'S EVERYTHING YOU NEED TO KNOW ABOUT OUR LIFETIME WARRANTY:

All 2019 (or newer) frames, including the Switch Infinity, are covered for life against damage due to manufacturing defects for the original purchaser. Paint and finish are covered for 1-year. We will repair or replace, at our discretion, any frame we deem defective. There are a few conditions: you must register it online at yeticycles.com and you must take it to an authorized Yeti Cycles dealer for processing. Warranty does not cover damage due to ordinary wear and tear, neglect or intentional destruction. From a slingshot or your truck.

If you happen to have a crash or non-warranty situation, we'll get you back on the trail with a reasonable replacement price. Same conditions as above.

Lifetime Warranty applies to all 2019 and newer frames (including the SB100). Model year 2018 and older frames will be covered under our previous warranty (5-year or 2-year based on time of purchase).

Simple as that. No fine print.

DISCLAIMER

Yeti Cycles is not responsible for any damages to you or others arising from riding, transporting or other use of your bicycle. In the event that your frame breaks or malfunctions, Yeti Cycles shall have no liability or obligation beyond the repair or replacement of your frame pursuant to the terms outlined in the warranty.

*If you have a warranty concern, please contact your authorized Yeti Cycles dealer.

YETI CYCLES

621 Corporate Circle, Unit
B Golden, CO 80401
(p) 303-278-6909
(f) 303-278-6906
yeticycles.com

BUSINESS HOURS

Monday-Friday
8AM-11:30AM (MST)
1:00PM-5:30PM (MST)