



OWNER'S MANUAL

2013 YETI 575

YETI CYCLES
600 Corporate Circle, Unit D
Golden, CO 80401
888.576.9384

www.yeticycles.com



TABLE OF CONTENTS

BRAND OVERVIEW	06
FRAME FEATURES	08
GEOMETRY	10
MAINTENANCE SCHEDULE	12
<i>SETUP</i>	
OVERVIEW	14
SHOCK SETUP	15
QUICK START GUIDE	16
CABLE/LINE SETUP	18
<i>TECHNICAL</i>	
ASSEMBLY OVERVIEW	20
CHIP SYSTEM	24
EXPLODED VIEWS	26
REBUILD KITS	28
<i>LEGAL</i>	
WARRANTY	30
CONTACT INFORMATION	31

CONGRATULATIONS ON YOUR PURCHASE OF A NEW YETI.

We are confident your new bicycle will exceed your expectations for value, performance, and ride quality. Each frameset and component has been custom specified and designed to enhance your riding experience. Whether you are a beginner cyclist, or a seasoned pro, your Yeti bicycle will provide endless hours of two-wheeled fun.

This model specific manual is designed to be used in conjunction with the general Yeti Owner's Manual and the manuals supplied by the suspension manufactures. If you did not receive the Yeti owner's manual or the manual provided by the suspension manufacturer download the materials off the Internet, or contact your local dealer.

Bicycling can be a hazardous activity even under the best of circumstances. Proper maintenance of your bicycle is your responsibility and when done properly helps reduce the risk of injury and damage to your bicycle.

Warning: Make sure you review and understand the warnings, instructions, and content of this manual and accompanying manuals for your bicycle.

Warning: Technological advances have made bicycles and bicycle components more complex and the pace of innovation is increasing. It is impossible for this manual or the accompanying manuals to provide all the information required to properly repair and/or maintain your bicycle. In order to help minimize the chances of an injury, it is critical for you to have work performed by an authorized Yeti retailer.

This manual outlines basic setup and maintenance recommendations of your new Yeti. Because it is impossible to anticipate every situation or condition that may occur during the assembly, setup, and maintenance of your bicycle, Yeti recommends that all service and repairs be performed by your local authorized Yeti Dealer.

This manual contains many "Warnings" and "Cautions" concerning the consequences of failure to maintain or inspect your bicycle. The word "Warning" indicates a potentially hazardous situation in which, if not avoided, could result in serious injury or death. The word "Caution" indicates a potentially hazardous situation in which, if not avoided may result in minor injuries or damage to your bicycle or a component of your bicycle. Be sure to read and understand all of the Warnings and Cautions listed in the manual.

THE 575 IS THE ORIGINAL ALL MOUNTAIN RIG.

1. YETI PURE TUBING
2. ISCG 03' TABS
3. HYDROFORMED REAR TRIANGLE
4. TAPERED INSET HEADTUBE (44MM/56MM)
5. REAR SHOCK BY FOX RACING SHOX
6. DROPOUTS 12MM X 142 THRU AXLE OR 135MM QR
7. CABLE STOPS FOR HEIGHT ADJUSTABLE SEATPOST
8. DIRECT MOUNT FRONT DERAILLEUR

1. Yeti pure tubing is custom butted and tapered 7005 aluminum. This makes the frame lightweight and strong without the use of gussets. The unique shape perfectly compliments the shape of the headtube for increased front-end stiffness.
2. Set up and run a 1x10 drivetrain with a ISCG '03 compatible chainguide cleanly and efficiently.
3. The re-designed full alloy rear triangle increases strength and stiffness while maintaining the same weight. Internal cable routing through the chainstay maximizes clearance between the chainstay, rear tire, and crankset.
4. Using our new inset headtube on the 575 allows for a larger headtube with more welding area, increased stiffness, and lower overall ride height.
5. The 575 uses a 2.0 inch stroke, 7.875 inch eye to eye shock, by Fox Racing Shox.
6. The Yeti chip system allows for an easy switch between a standard 135mm QR or the 142mm x 12mm Shimano thru-axle system.
7. Dedicated cable stops for a height adjustable seat post make routing the line clean and easy. Enhance your trail riding experience on the 575 with a dropper post.
8. Mount a direct mount (E-type) front derailleur to the 575 with ease.

GEOMETRY

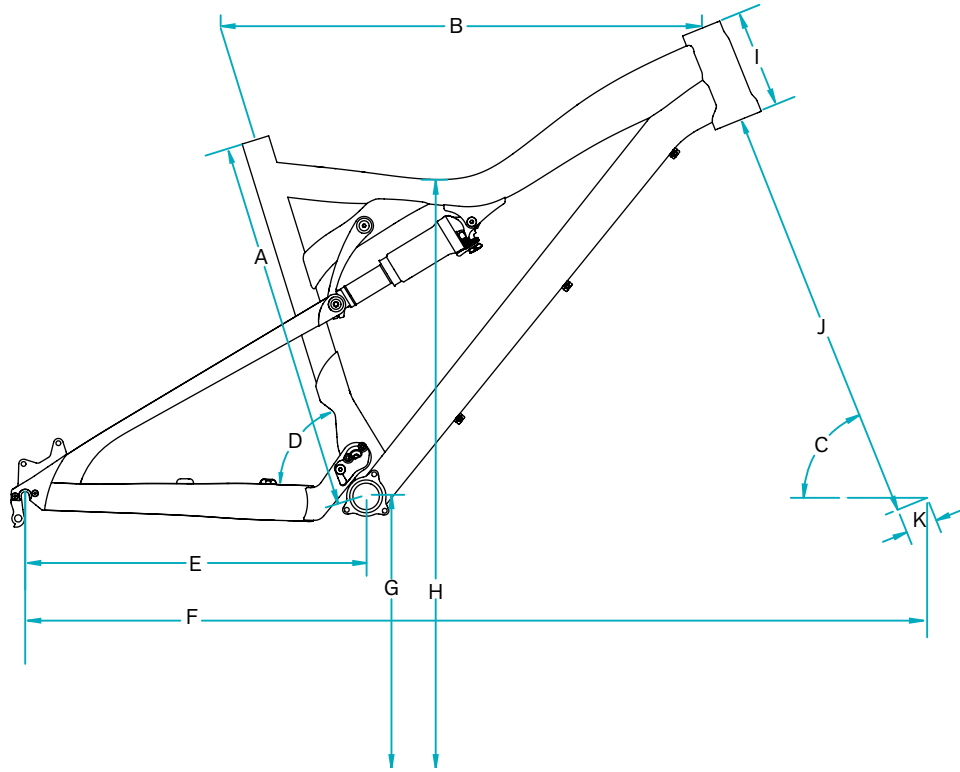

FIT

X-SMALL	5'0" (153 CM) - 5'3" (160 CM)
SMALL	5'3" (160 CM) - 5'7" (171 CM)
MEDIUM	5'7" (171 CM) - 5'11" (180 CM)
LARGE	5'11" (180 CM) - 6'3" (191 CM)
X-LARGE	6'3" (191 CM) - 6'6" (198 CM)

FOX 32 150 MM FORK

	XS	SM	MD	LG	XL
A	16.0	17.5	18.5	20.5	20.5
B	21.8	22.8	23.8	24.8	25.8
C	68.0	68.0	68.0	68.0	68.0
D	72.8	72.8	72.8	72.8	72.8
E	16.9	16.9	16.9	16.9	16.9
F	42.4	43.5	44.5	45.6	46.4
G	13.3	13.3	13.3	13.3	13.3
H	28.5	29.1	29.1	29.1	29.1
I	4.1	4.9	4.9	5.1	5.1
J	20.5	20.5	20.5	20.5	20.5
K	1.5	1.5	1.5	1.5	1.5

FOX 34 150 MM FORK

	XS	SM	MD	LG	XL
A	16.0	17.5	18.5	20.5	20.5
B	21.9	22.8	23.8	24.8	25.6
C	67.6	67.6	67.6	67.6	67.6
D	72.4	72.4	72.4	72.4	72.4
E	16.9	16.9	16.9	16.9	16.9
F	42.5	43.5	44.5	45.6	46.4
G	13.4	13.4	13.4	13.4	13.4
H	28.6	29.1	29.1	29.1	29.1
I	4.10	4.90	4.90	5.50	5.50
J	20.8	20.8	20.8	20.8	20.8
K	1.5	1.5	1.5	1.5	1.5

*All measurements are in inches

KEEP YOUR NEW YETI FRESH AND CLEAN

OVERVIEW

Following these guidelines will help maintain the performance of your bicycle and prevent more serious problems from arising. It is important to remember that service intervals can vary depending on climate, trail conditions and riding frequency. If you are unsure about working on your own bicycle, contact your authorized Yeti Dealer or visit the repair help section at www.parktool.com for more information on general bicycle maintenance.

SCHEDULE

	WEEKLY	MONTHLY	3 MONTHS	ANNUALLY
CLEAN AND LUBE CHAIN	■			
CHECK TIRE PRESSURE	■			
CLEAN BIKE OF MUD AND DEBRIS	■			
CHECK BRAKE FUNCTION	■			
CHECK SHOCK PRESSURE, IF APPLICABLE	■			
CHECK FOR LOOSE BOLTS AND TIGHTEN, IF NECESSARY	■			
CHECK HEADSET AND TIGHTEN / LOOSEN, IF NECESSARY		■		
THOROUGHLY CLEAN PIVOT POINTS WITH A RAG (DO NOT LUBRICATE)		■		
REPLACE BRAKE PADS, IF NECESSARY			■	
CHECK TIRES FOR WEAR			■	
CHECK SPOKE TENSION AND RETENTION, IF NECESSARY			■	
CHECK CHAIN FOR WEAR AND REPLACE IF NECESSARY			■	
COMPLETE TUNE-UP PERFORMED BY AN AUTHORIZED YETI DEALER				■

TORQUE

Yeti strongly recommends using a torque wrench when assembling your frame. Torque specifications for individual parts on the 575 are listed below, as well as in the step by step assembly instructions later in the manual. For general bicycle maintenance please consult the torque specifications of the manufacture's component you are adjusting.

KEY TORQUE SPECS

PART NUMBER	DESCRIPTION	TORQUE (IN/LB)
300030110	BOLT-TI-MALE M6X1 12 MM	90-95
HNA0000ABA0000000005	BOLT-ALLOY-MALE M6X1 12MM	60-65
300030189	PIVOT PIN BOLT M10 X 1 X 22	115-125
300030194	BOLT CAP SCKT HD M4X.7X10	25-30
300030139	BOLT FLAT HD M4X.7X16	5-10

SHOCK SETUP

YETI TIPS

Inspect your shock for any visible damage. If oil is leaking or you notice any damage to the surfaces or seals, please contact the Fox Racing Shox service center for repair at 800.FOX.SHOX.

Shock set-up can fluctuate greatly based on the rider. The set-up guide is intended as a base line to get the rider started. Experiment with your settings to find the set-up that works best for you.



TOOLS NEEDED

- Shock Pump
- Tape Measure



01. AIR PRESSURE

The main air spring controls the sag of the shock. For the 575 to ride properly it is important to setup the shock with the correct amount of sag. For general riding the 575 works best with 20-30% (10-15MM) of shock sag. To increase the sag reduce the main spring air pressure. To reduce the sag increase the main spring air pressure.

02. SAG

Once you have set your baseline air pressure you need to measure the sag. To measure the sag slide the travel indicator (O-Ring) up against the shock body. With a friend supporting the bike, sit on the saddle (do not bounce) and allow your body weight to compress the shock. Once you have compressed the shock, get off the bike and measure the distance between the shock body and the new position of the travel indicator (O-Ring). This is your sag.



03. REBOUND

The rebound adjustment has 14 clicks of adjustment. The rebound knob is the red adjustment dial located above the blue compression damping adjustment lever. As a general rule, adjustments that are too fast (counter-clockwise adjustment) will produce a springy ride with excessive kick-up of the rear end causing a bucking sensation. Adjustments that are too slow (clockwise adjustment) will cause packing of the rear wheel indicated by a sluggish ride feeling ride.

Slower rebound- turn the knob clockwise
Faster rebound- turn the knob counter-clockwise



SHOCK SETUP



04. COMPRESSION DAMPING

The compression dampening has three levels of adjustment and is controlled by the blue lever on the shock. The "climb" mode engages the firmest low-speed compression setting for maximum pedaling efficiency. The "trail" mode engages a moderate low-speed compression setting for an optimal blend of pedaling efficiency and bike control, on various riding terrain. Finally, the "descend" mode sets the low-speed compression setting to fully open, for maximum bike control and shock absorbency on steep, aggressive descents.

05. TRAIL ADJUST

The trail adjust dial controls the "trail" mode low speed compression adjustment. It has three levels of adjustment and is controlled by the black dial on the shock body. Turning the dial clockwise increases low speed compression damping, making the shock feel stiffer under low speed compressions. Turning the dial counter-clockwise will decrease low speed compression damping, making the shock feel softer under low speed compressions. Please note this adjustment only affects the shock performance while riding in "trail" mode.

QUICK START GUIDE - CTD ADJUST

ADJUSTMENT	SETTING
AIR SPRING SETTING (PSI)	RIDER WEIGHT PLUS 20-30 PSI
MEASURED SAG (MM)	10-15
REBOUND	*5 CLICKS
COMPRESSION DAMPING	BASED ON TERRAIN
TRAIL ADJUST	POSITION 2

**All clicks are counted clockwise, rotating from the all the way out or counter - clockwise dial position.*



CABLE SETUP

YETI TIPS

The 575 has full cable housing. By using full cable housing, we have eliminated break points in the line of your shifter housing. This allows riders to experience better overall shifting performance by reducing the entrance of unwanted elements such as sweat and sediment. Use of full cable housing helps prevent corrosion from the elements and keeps the shifting smoother for a longer period of time.

The staff at Yeti are sold on riding with a height adjustable seat post so we included specific cable guides for the post's line on the 575. Run the line from your remote through the cable stop on the non-drive side of the top tube for a clean set-up. If you haven't tried a dropper on your 575, we strongly recommend you do, as it makes trail riding even more fun.

Caution: The failure to properly route shifter housing can cause malfunction of the shift mechanism and unexpected shifting of gears.



01. REAR DERAILLEUR

Fit the housing from the rear shifter across the head tube and into the cable stops on the down tube. There are three cable stops on the bottom of the down tube, each with three positions to secure housing. Fit the rear housing line through these stops using the middle position. Next, route the housing over the bottom bracket and into the drive side chainstay. Be sure to run the housing through the guide on the front derailleur mount before inserting it into the chainstay. Push the housing through the chainstay and loop into the rear derailleur to finish.



02. FRONT DERAILLEUR

Fit a piece of housing from the front shifter across the head tube and into the three cable stops on the down tube. Use the position closest to the drive side for the front derailleur housing. Next, route the housing under the bottom bracket and into the two position stop under the chainstay yoke. The 575 is only compatible with Shimano front derailleurs, so use the position closest to the drive side of the bike. Ensure the housing loops into the chainstay stop to allow enough slack when the suspension is compressed. Run the wire cable through the housing and attach to the derailleur to finish.



03. REAR BRAKE

The rear brake line loops across the head tube and into the cable stops on the down tube. Use the position closest to the non-drive side of the frame on the cable guides for the rear brake line. Next, route the brake line over the bottom bracket shell and across the non-drive chainstay. Ensure the line is finished on the inside of the seatstay when attached to the caliper body. This will prevent the brake line from being compromised if the bike or rider falls.

ASSEMBLY

YETI TIPS

Make sure your tools are in good condition. A worn allen key can round the hex on a bolt not allowing for proper torque.

Torque settings are listed throughout the instructions. It is also important to prep all bolt threads. The instructions denote whether to use a Loctite compound or grease.

Warning: Service on Yeti bicycles requires special knowledge and tools. Yeti Cycles recommends that all service and repairs be performed by an authorized Yeti Dealer

TOOLS NEEDED

- Dead blow hammer
- Two - 5mm allen keys
- Two - 4mm allen keys
- 3mm allen key
- Guide pin tool
- Grease
- Blue loctite
- Purple loctite



01.

Install two M4x10mm bolts into the bottom of the dogbone. Prep the threads with blue loctite and torque the bolts tight enough to hold the bearings in place. The bolts will be torqued to spec later in the assembly.



02.

Use a dead blow hammer to install two 15mm reducers into the lower portion of the shock.



03.

Install the shock onto the frame. Insert a 31 mm alloy female bolt with washer through the drive side of the frame and shock. Use an alloy male bolt prepped with purple loctite on the non-drive side and tighten with two 4mm allen keys.

Torque to 60-65 in/lb.



04.

Install the dogbone onto the frame. Insert a 40.5 mm alloy female bolt with washer through the drive side of the frame and the dogbone. The fox guide pin tool and a dead blow hammer can be used help guide any female bolts through the frame and its components. Use an alloy male bolt prepped with purple loctite on the non-drive side and tighten with two 4mm allen keys.

Torque to 60-65 in/lb.



**05.**

Align the shock and dogbone. Orient the lower portion of the shock between the lower bearings on the dogbone. If necessary, loosen the pinch bolts on the dogbone to allow the bearings to move and accommodate the shock.

**06.**

Slide the swingarm over the main pivot bore, using the grooves in the swingarm to properly align over the bore.

**09.**

Prep an M6x12mm male Ti bolt with blue loctite and install into the 57.5mm Ti stud.

**10.**

Use the fox guide pin tool and a dead blow hammer to install the assembly created in step 9 through the seatstays, dogbone, and shock. Use a Ti male bolt prepped with blue loctite on the non-drive side and tighten with two 5mm allen keys.

Torque to 90-95 in/lb.

**07.**

Use the fox guide pin to align and hold the seatstays, dogbone, and shock together. Use a dead blow hammer to push the pin through the above mentioned components.

**08.**

Prep the main pivot pin (shaft) and bolt (threads) with grease. Install the female pivot pin from the drive side of the bike. Use a dead blow hammer to push the pin into place. Once in place, install and tighten the male pivot bolt with two 5mm allen keys.

Torque to 115-125 in/lb.

**11.**

Check the alignment of the seatstays, dogbone, and shock. Ensure there is equal spacing between the dogbone and seatstays on both sides of the frame. Tighten both dogbone pinch bolts with a 3mm allen key.

Torque to 25-30 in/lb.

**12.**

Insert the front derailleur mount into the main pivot area of the rear triangle. Fasten to the frame using a 16.5mm female alloy bolt and an alloy male bolt prepped with purple loctite.

Torque to 60-65 in/lb.



CHIP SYSTEM



01.

Use a 2.5mm allen key to loosen the two M4x9mm flat head bolts holding the QR insert derailleur hanger in place. Remove the bolts and the QR insert from the frame. Repeat the process for the bolts and the non drive QR insert.



03.

Fit the 12MM non-drive insert into the groove on the inside of the non-drive side chainstay. The insert should be flush with the chainstay. Next, fit the non-drive 12mm cap through the chainstay and into the insert from the outside of the non-drive side chainstay. To finish, use a 2.5MM allen key to attach the two dropout pieces to the swingarm with two M4x10MM flat head bolts. Prep the bolts with blue loctite and insert them into the non-drive cap, through the swingarm and into the insert.



02.

Fit the 12MM insert hanger into the groove on the inside of the drive side chainstay. The hanger should be flush with the chainstay. Next, insert the 12mm drive cap through the chainstay and into the hanger from the outside of the drive side chainstay. To finish, use a 3MM allen key to attach the two dropout pieces to the swingarm with two M4x15MM cap bolts. Prep the bolts with blue loctite and insert them into the drive cap, through the swingarm and into the hanger.



04.

Insert the M4x6MM custom cap bolt into the top of the drive cap. This bolt will be used to set the position of the Shimano 142x12MM axle. Refer to Shimano specifications for exact instructions on proper axle operations.

Torque for all chip system bolts: 15-20 in/lb

EXPLODED VIEWS

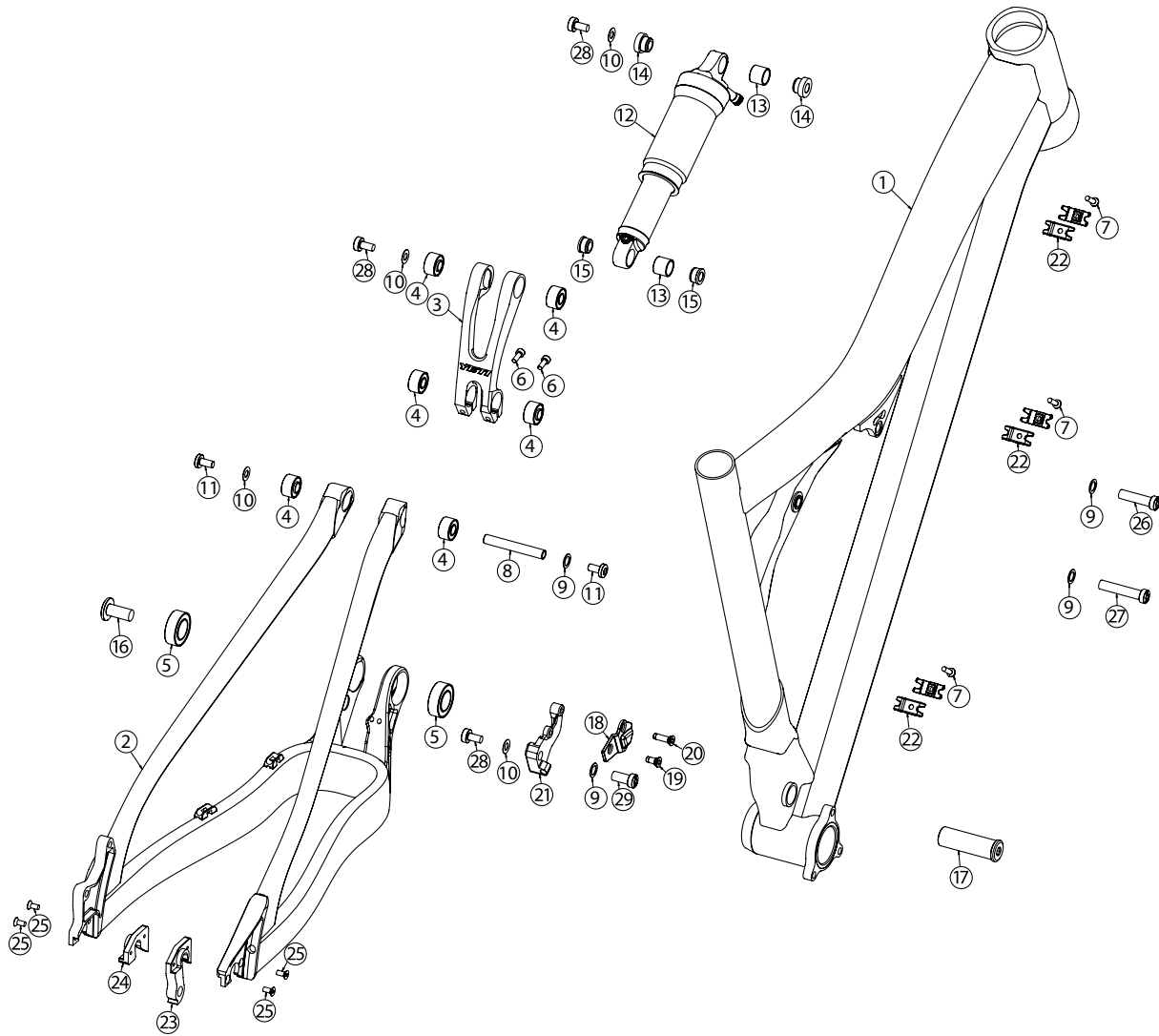

	PART #	DESCRIPTION	QTY
1	NA	575 FRONT TRIANGLE	1
2	NA	575 SWINGARM	1
3	300040235	575 DOGBONE	1
4	300020032	BEARING 398 2RS MAX DOUBLE ROW	6
5	300020030	BEARING 3903 2RS MAX	2
6	300030194	BOLT CAP SCKT HD M4X.7X10	2
7	300030139	BOLT FLAT HD M4X.7X16	3
8	300030191	STUD-TI-FEMALE 8X57.5MM	1
9	300030069	WASHER 8.5X12.5X0.5 MM	4
10	300030062	WASHER 6.5X12.5X0.5 MM	4
11	300030110	BOLT-TI-MALE M6X1.12 MM	2
12	NA	FOX RP23 [7.875"X2.0"]	1
13	300020020	GARLOCK DP BUSHING .5".5"	2
14	300020034	REDUCER FOX 8X22MM	2
15	300020035	REDUCER 8MM X 7.5MM	2
16	300030189	PIVOT PIN BOLT M10 X 1 X 22	1
17	300030188	PIVOT PIN 17X7.5/10X1THRD 52.4	1
18	100130040	FD E-TYPE COVER PLATE	1
19	300030140	CUSTOM BOLT M5X12	1
20	300030141	CUSTOM BOLT M5X18	1
21	HNA0575ABA0000000000	2012 575 FD MOUNT	1
22	300040398	BOLT-ON CABLE GUIDE TRIPLE	3
23	300060061	QR INSERT DER HANGER	1
24	300040386	QR INSERT NON-DRIVE	1
25	300030221	BOLT FLAT HEAD M4X.7X9	4
26	HNA00000ABA0000000001	BOLT-ALLOY-FEMALE 8.0X31MM	1
27	HNA00000ABA0000000002	BOLT-ALLOY-FEMALE 8.0X40.5MM	1
28	HNA00000ABA0000000005	BOLT-ALLOY-MALE M6X1.12MM	3
29	HNA00000ABA0000000000	BOLT-ALLOY-FEMALE 8.0X16.5MM	1

REBUILD KITS

PART #	DESCRIPTION	QTY
HNA0575M00AA00MST0000	575 MASTER REBUILD KIT	1
300020020	GARLOCK DP BUSHING .5"X.5"	2
300020030	BEARING 3903 2RS DOUBLE ROW	2
300020032	BEARING 398 2RS MAX DBL ROW	6
300030062	WASHER 6.5X12.5X0.5 MM	4
300030069	WASHER 8.5X12.5X0.5 MM	4
300030110	BOLT-TI-MALE M6X1 12MM	2
300030139	BOLT FLAT HD M4X7X16	3
300030188	PIVOT PIN 17X7.5/10X1THRDR 52.4	1
300030189	PIVOT PIN BOLT M10 X 1 X 22	1
300030191	STUD-TI-FEMALE 8X57.5MM	1
300030194	BOLT CAP SCKT HD M4X.7X10	2
HNA0000ABA00000000000	BOLT-ALLOY-FEMALE 8.0X16.5MM	1
HNA0000ABA000000000001	BOLT-ALLOY-FEMALE 8.0X31MM	1
HNA0000ABA000000000002	BOLT-ALLOY-FEMALE 8.0X40.5MM	1
HNA0000ABA000000000005	BOLT-ALLOY-MALE M6X1 12MM	3
HNA0575M00AA00BRG0000	575 BEARING REBUILD KIT	1
300020030	BEARING 3903 2RS DOUBLE ROW	2
300020032	BEARING 398 2RS MAX DBL ROW	6

WARRANTY

YETI LIMITED (5) FIVE YEAR FRAME WARRANTY

(applies to SB4.5c / SB5c / Beti SB5c / SB6c / ASRc / Beti ASRc)

Yeti Cycles will repair or replace, at its option, any frame it determines to be defective due to defective materials and/or workmanship. The (5) one year limited warranty is conditioned upon the bicycle being ridden under normal conditions and having been properly maintained. This warranty does not apply to the components attached to the frameset such as suspension components, wheels, drive train, brakes, seatpost, handlebar and stem. This warranty applies only to the original owner and is non-transferable. This warranty is void if the bicycle was not properly assembled by an authorized Yeti dealer.

YETI LIMITED (2) TWO YEAR FRAME WARRANTY

(applies to ARC-C / AS-R 5C / AS-R 5A / SB66-A / SB66-C / SB95 / SB95-C / 575 / ARC / Big Top 29'R)

Yeti Cycles will repair or replace, at its option, any frame it determines to be defective due to defective materials and/or workmanship. The (2) two year limited warranty is conditioned upon the bicycle being ridden under normal conditions and having been properly maintained. This warranty does not apply to the components attached to the frameset such as suspension components, wheels, drive train, brakes, seatpost, handlebar and stem. This warranty applies only to the original owner and is non-transferable. This warranty is void if the bicycle was not properly assembled by an authorized Yeti dealer.

ADDITIONAL CONDITIONS

These limited warranties do not apply to normal wear and tear, nor to claimed defects, malfunctions or failures that result from abuse, neglect, improper assembly, improper maintenance, alteration, collision, crash or misuse. The original owner shall pay all labor charges connected with the repair or removal of all components. Under no circumstance does this limited warranty include the cost of travel or shipment to and from an authorized Yeti dealer. In order to exercise your rights under these limited warranties, the bicycle or frameset must be presented to an authorized Yeti dealer, together with proof of purchase.

**The above warranties have been in effect since January 2012. For warranty information on Yeti frames sold prior to that date please consult your local authorized dealer.*

NO FAULT REPLACEMENT POLICY

Yeti Cycles will make replacement parts available at a minimum charge to the original owner in the event of a crash or any other non-warranty situation. Yeti Cycles does this at its sole discretion and reserves the right to refuse this offer.

PRODUCT LIFE CYCLE

Every YETI frameset has a useful product life cycle. The length of that useful product life cycle will vary depending on the construction and the materials of the frameset, maintenance and care the frameset receives, and the amount and type of use the frameset is subjected to over its life. YETI recommends that an authorized YETI dealer should inspect the frame for stress annually. Frame stress could cause potential failure and the signs are usually apparent in the form of cracks, fracture lines, deformation, dents, and any other visual indicators of abnormality. These safety checks for frame stress are important to prevent accidents, injury to the cyclist, and product failure of a YETI frameset.

DISCLAIMER

YETI Cycles is not responsible for any damages to you or others arising from riding, transporting or other use of your bicycle. In the event that your frame breaks or malfunctions, YETI Cycles shall have no liability or obligation beyond the repair or replacement of your frame pursuant to the terms outlined in the warranty.

**If you have a warranty concern, please contact your authorized Yeti dealer.*

YETI CYCLES

621 Corporate Circle, Unit B
Golden, CO 80401
(p) 303-278-6909
(f) 303-278-6906
www.yeticycles.com

BUSINESS HOURS

Monday-Friday
8AM-11:30AM, 1:00PM-5:30PM
(Mountain Time)